

# Reverse Loops with American Flyer Trains

Norbert Doerry

Version 1.0 of March 2014

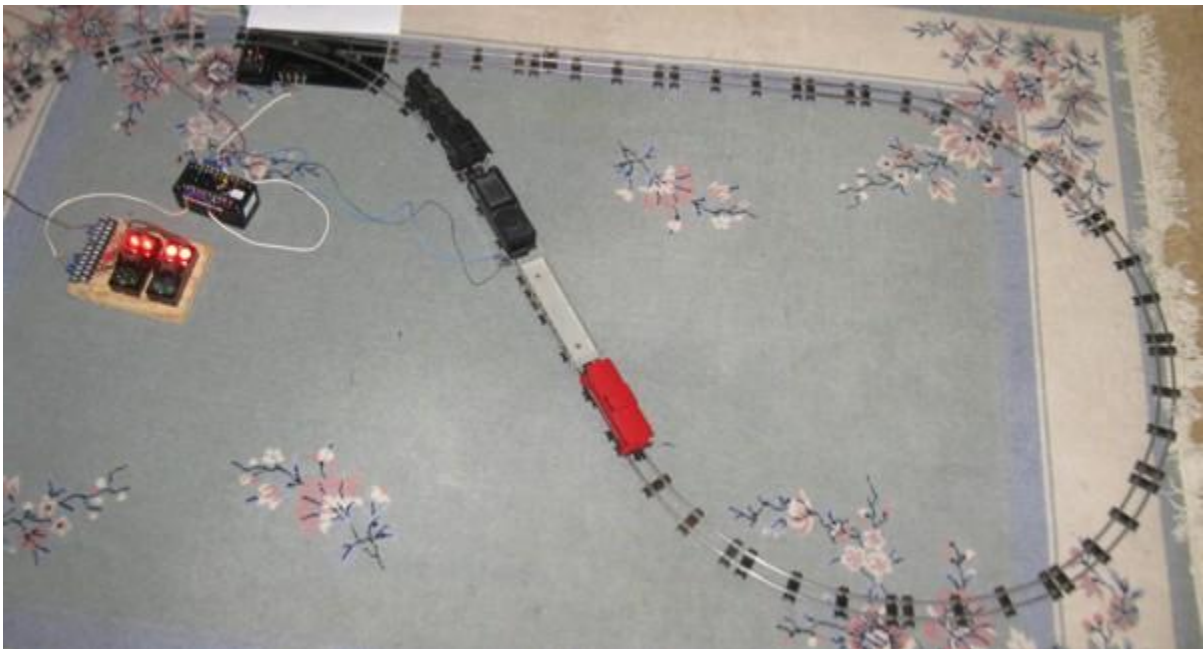

doerry@aol.com

<http://doerry.org/norbert/train/AFtrain.htm>

Copyright (C) 2014 Norbert H. Doerry  
Permission is granted to copy, distribute and/or modify this document under  
the terms of the GNU Free Documentation License, Version 1.3 or any later  
version published by the Free Software Foundation; with no Invariant  
Sections, no Front-Cover Texts, and no Back-Cover Texts.  
A copy of the license is included in the section entitled "GNU Free  
Documentation License".

# Table of Contents

Table of Contents .....	iii
Table of Figures .....	iv
History .....	iv
1. Introduction.....	1
2. Reverse Loops in AC Operations.....	3
3. Reverse Loops in DC Operations.....	7
4. Automating Reverse Loop and Switch Control .....	9
4.1 AC Operation.....	9
4.2 DC Operation.....	13
Appendix A: Track Trips .....	15
A.1 Pressure Trips (AF 697).....	15
A.2 "Shoe" Trips (AF 696).....	16
A.3 Current Trip: Electric Track Trip (AF 670) .....	18
A.4 Current Trip: Electronic .....	21
A.5 Infrared Trip: Reflective .....	23
A.6 Infrared Trip: Beam Breaking.....	24
Appendix B: Track Switch Direction Sensor.....	27
B.1 Indirect Sensing using Atlas Snap Relay .....	27
B.2 Indirect Sensing using Opto-Isolators .....	28
B.3 Direct Sensing using reed switch .....	29
B.4 Direct Sensing using hall effect sensor .....	30
Appendix C: GNU Free Documentation License .....	31

## Table of Figures

Figure 1: Reverse Loop.....	1
Figure 2: Reverse Loop Approach that doesn't work.....	3
Figure 3: DPDT Switch solution for AC Reverse Loop .....	4
Figure 4: 695 Reverse Loop Relay .....	4
Figure 5: Atlas Snap-Relay 200 solutions for AC Reverse Loop .....	5
Figure 6: Atlas Snap-Relay 200 with high current relay for AC Reverse Loop .....	5
Figure 7: Atlas Snap Relay 200 .....	6
Figure 8: Atlas Snap-Relay 200 solutions for DC Reverse Loop .....	7
Figure 9: Atlas Snap-Relay 200 solutions for two DC Reverse Loops.....	8
Figure 10: Automatic Reverse Loop and Switch Control Block Diagram .....	9
Figure 11: AC Operation Automatic Reverse Loop and Switch Control .....	9
Figure 12: AC Operation Switch Control Logic Flow.....	10
Figure 13: Reverse Loop Control Schematic (Part 1).....	11
Figure 14: Reverse Loop Control Schematic: Switch Interface (Part 2).....	12
Figure 15: DC Operation Automatic Reverse Loop and Switch Control .....	13
Figure 16: Pressure Track Trip #697 .....	15
Figure 17: Shoe Track Trip #696.....	16
Figure 18: 696 Isolation Circuit.....	16
Figure 19: Track Connection for 696 Track Trip.....	17
Figure 20: Electric Track Trip #670 .....	18
Figure 21: Using the #670 Electric Track Trip .....	18
Figure 22: A.C. Gilbert instructions for no. 26671 Electric Track Trip .....	19
Figure 23: A.C. Gilbert Instructions for no. 26672 Electric Track Trip .....	19
Figure 24: Home-made electric track trip .....	20
Figure 25: Electronic Current Track Trip .....	21
Figure 26: "Brick" Transformer (Before conversion to a current transformer) .....	21
Figure 27: Current Transformer Connection to Track .....	22
Figure 28: Reflective IR trip (Sensa-Trak II from TCH Technology).....	23
Figure 29: Reflective IR trip installed in track-side building .....	23
Figure 30: Beam Breaking IR Track Trip.....	24
Figure 31: Circuit for Beam Breaking IR Track Trip .....	25
Figure 32: Example of Atlas Snap Relays used for Switch Direction Sensing.....	27
Figure 33: Example of opto-isolators used for Switch Direction Sensing .....	28
Figure 34: Schematic for opto-isolator indirect Switch Direction Sensing .....	28
Figure 35: Magnetic Reed Switch.....	29
Figure 36: Example of magnetic reed switch used for Switch Direction Sensing .....	29
Figure 37: Hall Effect Sensor (MP101301) .....	30
Figure 38: Example of hall effect sensor used for Switch Direction Sensing.....	30

## History

Version 1.0: "Reverse Loops with American Flyer Trains" March 2014 by Norbert Doerry: published <http://www.doerry.org>.

## 1. Introduction<sup>1</sup>

Reverse loops are a special case of a track layout that require careful consideration in powering the track in either AC or DC operations. A reverse loop exists whenever a train traveling in the forward direction can traverse the same piece of track in opposite directions. Figure 1 is a typical example of a reverse loop and highlights its problem. Unless special precautions and controls are implemented, a reverse loop will result in a short circuit. Each rail of the loop connects the right and left rails of the track entering the loop as indicated by the black and red rails connecting to each other in the circle.

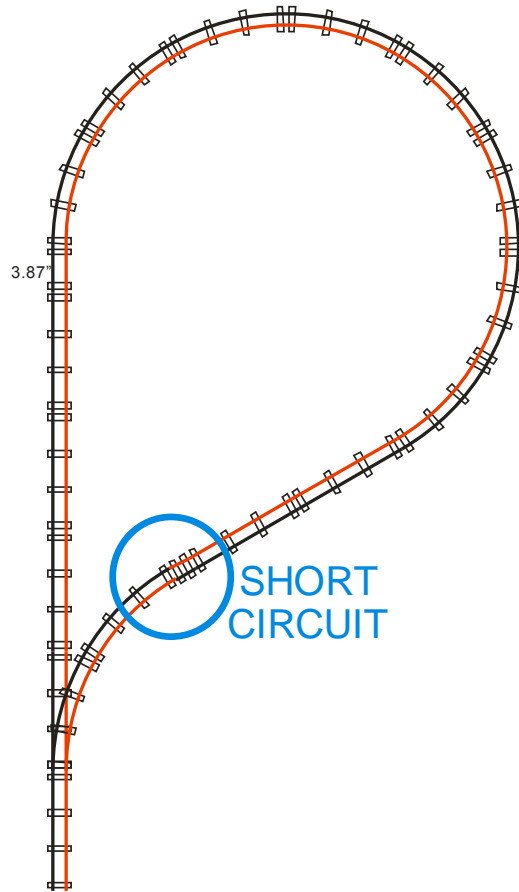

**Figure 1: Reverse Loop**

This document version only addresses reverse loops and does not directly address wyes which also exhibit similar electrical problems as reverse loops. I will leave addressing wyes for a future revision.

Please contact the author if you find any errors. Also, feel free to suggest improvements or additions to this document. Revisions will be produced as needed to correct errors and add more material.

---

<sup>1</sup> *American Flyer* and *A.C. Gilbert* are trademarks of Lionel Trains, LLP. This document is neither authorized nor approved by Lionel Trains, LLP.

(This page left intentionally blank)

## 2. Reverse Loops in AC Operations

For AC operation, one may be tempted to solve the short circuit problem by simply inserting 2 insulating pins as shown in Figure 2 (a). While this eliminates the short circuit when a locomotive is not present, it does not work because the track pickups on the locomotive tender (or a diesel engine) generally connect to at least two wheels and are staggered. As shown in Figure 2 (b), when one of the tender trucks crosses over the insulating pins, the two wheels will create a short circuit. Typically this short circuit will be of short duration as the locomotive coasts forward a small amount. Then, as shown in Figure 2 (c), both track pickups are connected to the same polarity, hence the locomotive will have no power and will stop.

A simple solution is shown in Figure 3. A toggle switch is manually thrown to reverse the track power connections at roughly the same time the direction of the track turnout (switch) is changed. While simple to implement, it does require the operator to remember to do two things at the same time.

Figure 4 demonstrates how to use the American Flyer 695 reverse loop relay along with a remote switch to automate the reversing of track power in the reverse loop. With this configuration, the controller for the remote switch also controls the reverse loop relay so that the polarity of the track in the reverse loop is always correctly maintained based on the direction of the turnout.

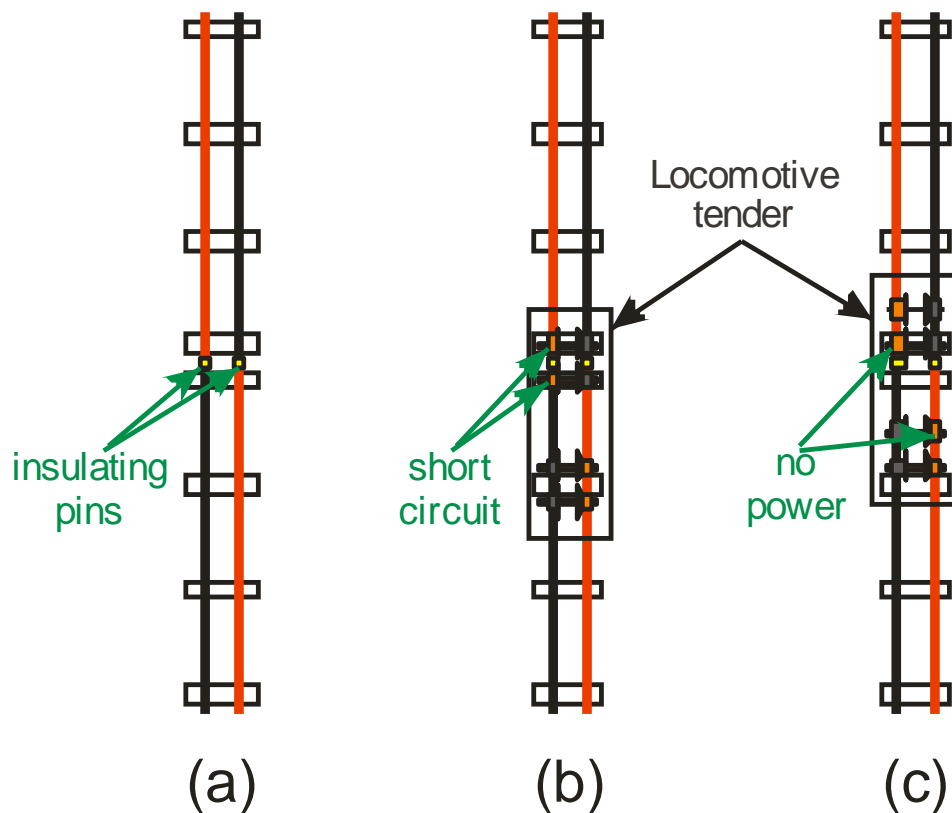
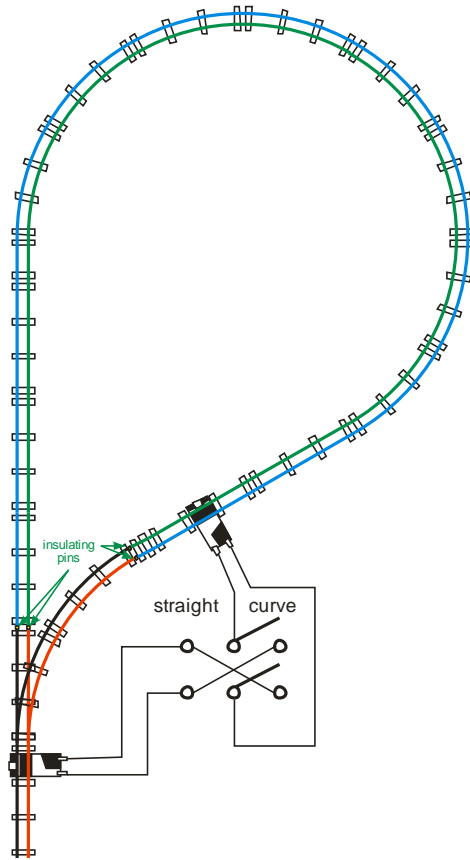
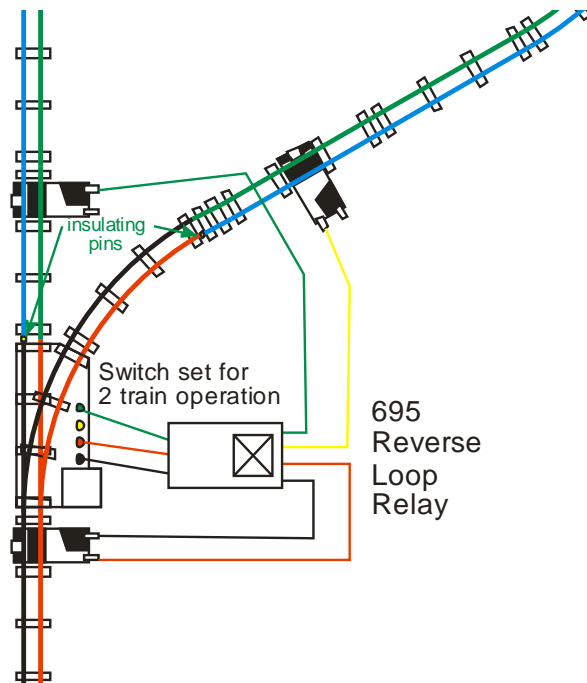

Figure 2: Reverse Loop Approach that doesn't work



**Figure 3: DPDT Switch solution for AC Reverse Loop**



**Figure 4: 695 Reverse Loop Relay**



While the 695 reverse loop relay works well, it also can be expensive. As an alternative the Atlas Snap-Relay 200 can be configured to emulate the 695 as shown in Figure 5 (a). An alternate solution for reverse loops shown in Figure 5 (b) does not rely on the contacts within the turn-out (remote switch) to power the "inside" rail and hence may have better reliability. One potential issue with the Atlas Snap-Relay 200 is that the rated current is not published. If you intend to operate the reverse loop with a high current locomotive such as a dual motor ALCO, the circuit shown in Figure 6 may be employed. This circuit consists of a 12 volt power supply (rectifier, filter capacitor, and voltage regulator) and a DPDT 12V relay with high current contacts that is controlled by the Atlas snap-relay 200. A picture of the snap-relay is shown in Figure 7.

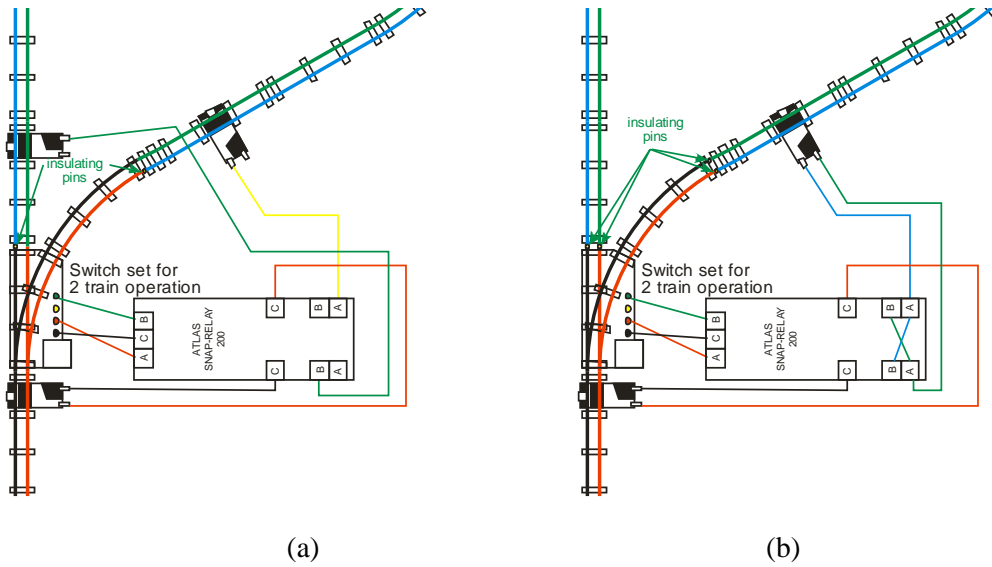

Figure 5: Atlas Snap-Relay 200 solutions for AC Reverse Loop

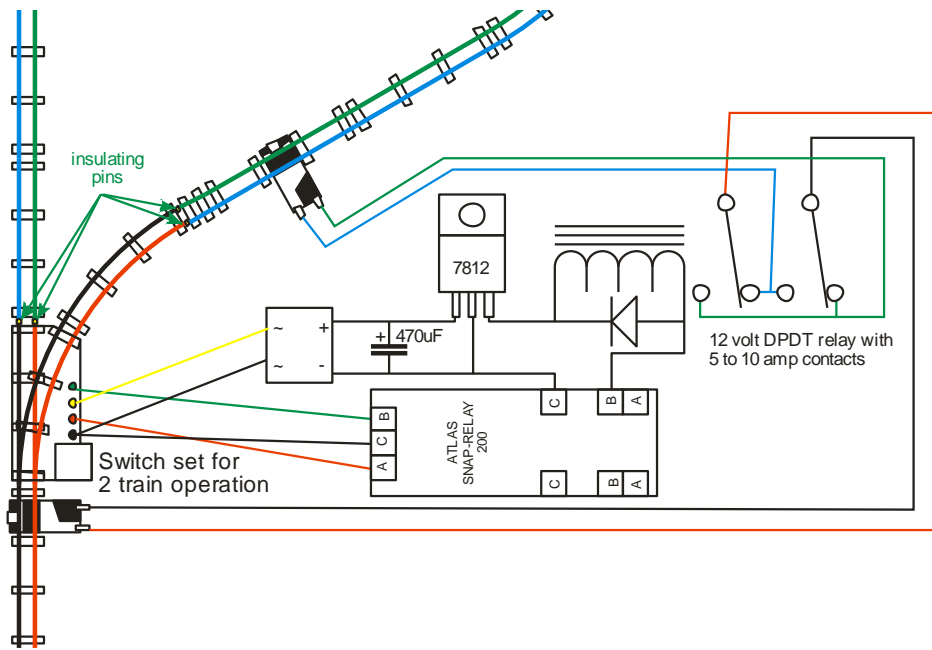

Figure 6: Atlas Snap-Relay 200 with high current relay for AC Reverse Loop

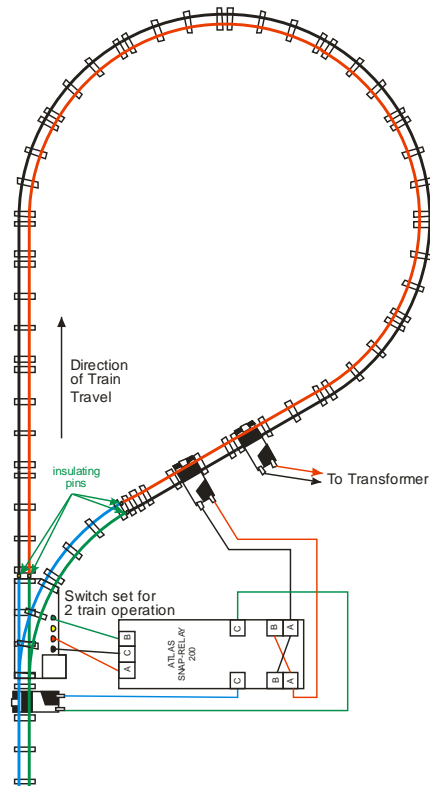

**Figure 7: Atlas Snap Relay 200**

One of the beneficial aspects of these AC implementations is that each reverse loop is an independently controlled subsystem. If problems are experienced, they generally can be localized and identified relatively easily.

### 3. Reverse Loops in DC Operations

Because train direction is determined by the polarity of the track voltage, different methods are required for DC operation as compared to AC operation. In DC operation an engine by convention travels forward when the rail on the right (when looking forward) is the positive rail. This means the polarity of the track leading to and from the reverse loop must switch while the train is in the reverse loop. The polarity of the track within the reverse loop can remain constant; the train will therefore always travel in the same direction through the reverse loop. Figure 8 shows how an Atlas Snap Relay can be used to switch the polarity of the track leading to the reverse loop.



**Figure 8: Atlas Snap-Relay 200 solutions for DC Reverse Loop**

A real layout generally will not have only one reverse loop; at least one other reverse loop (or wye) is needed to restore the original direction of the engine. Otherwise the reverse loop can only be visited once when a train travels only in the forward direction. Control of the polarity of the connecting single track can still be established with a single Atlas Snap Switch if the track switches for the two reverse loops are electrically connected to one another so that they both switch at the same time as shown in Figure 9. This configuration still requires the operator to change the direction of the switches while the train is in the reverse loop.

Note: The methods employed in this document for DC operation will also work for AC Operation. (However, the methods for AC operation will NOT work for DC)

One of the drawbacks to the DC implementations is that multiple reverse loops must be integrated to control the polarity of the track leading to the reverse loop. This additional complexity may complicate troubleshooting should problems be experienced.

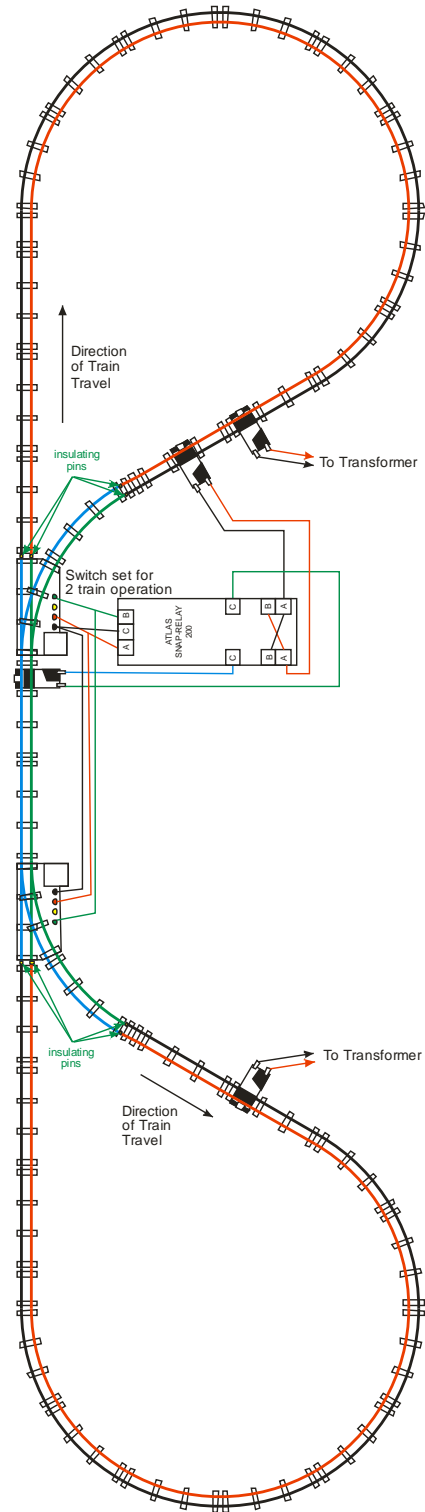

Figure 9: Atlas Snap-Relay 200 solutions for two DC Reverse Loops

## 4. Automating Reverse Loop and Switch Control

In the previous section, operation of the train through the reverse loop required operator action. This section details how operation of a reverse loop can be fully automated; the train operator need only to watch and enjoy the trains. Figure 10 depicts a block diagram of the automated control. The previous sections provided solutions for "Switch Position Detection" and "Reverse Loop Track Power." This section will add the functionality of the track trips and switch controller.

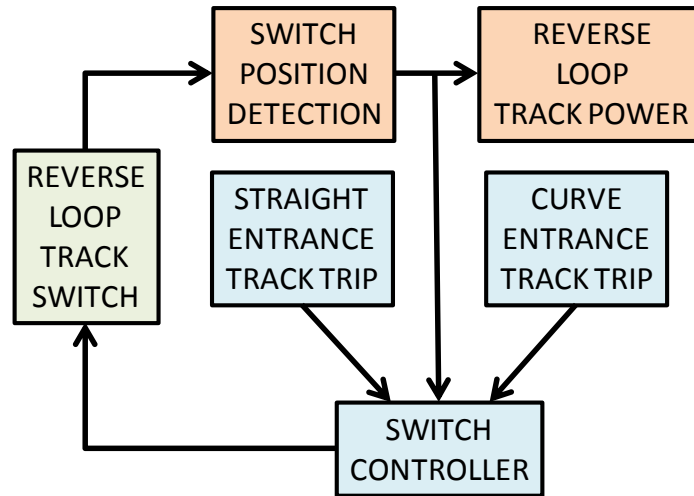

Figure 10: Automatic Reverse Loop and Switch Control Block Diagram

### 4.1 AC Operation

Figure 11 illustrates how operation of a reverse loop can be fully automated. The reverse loop track power polarity is determined by the position of the track switch (turn-out). The switch is automatically thrown to the proper direction based on the current direction of the switch and the activation of the appropriate track trip. Figure 12 provides the logic flow diagram for the control of the track switch.

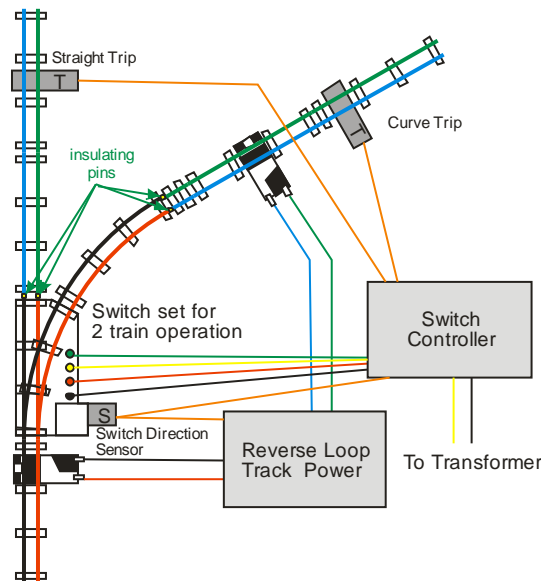
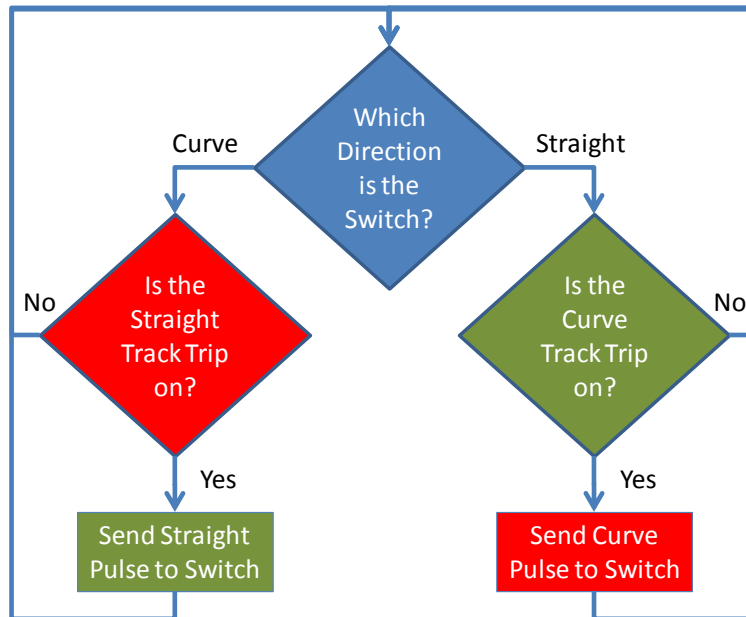

Figure 11: AC Operation Automatic Reverse Loop and Switch Control



**Figure 12: AC Operation Switch Control Logic Flow**

Figure 13 and Figure 14 are schematics of a circuit that implements Figure 11 and Figure 12. The NOR gates implement the decisions of the logic flow of Figure 12. The two 555 timers create the pulses for throwing the track switch. The two relays in Figure 14 energize the switch coils based on the pulses generated by the 555 timers. The relay in Figure 13 implements the Reverse Loop Track power block from Figure 11.

Appendix A provides more details on the different types of track trips available for sensing the presence of a train. Appendix B provides different methods for implementing the switch direction sensor.

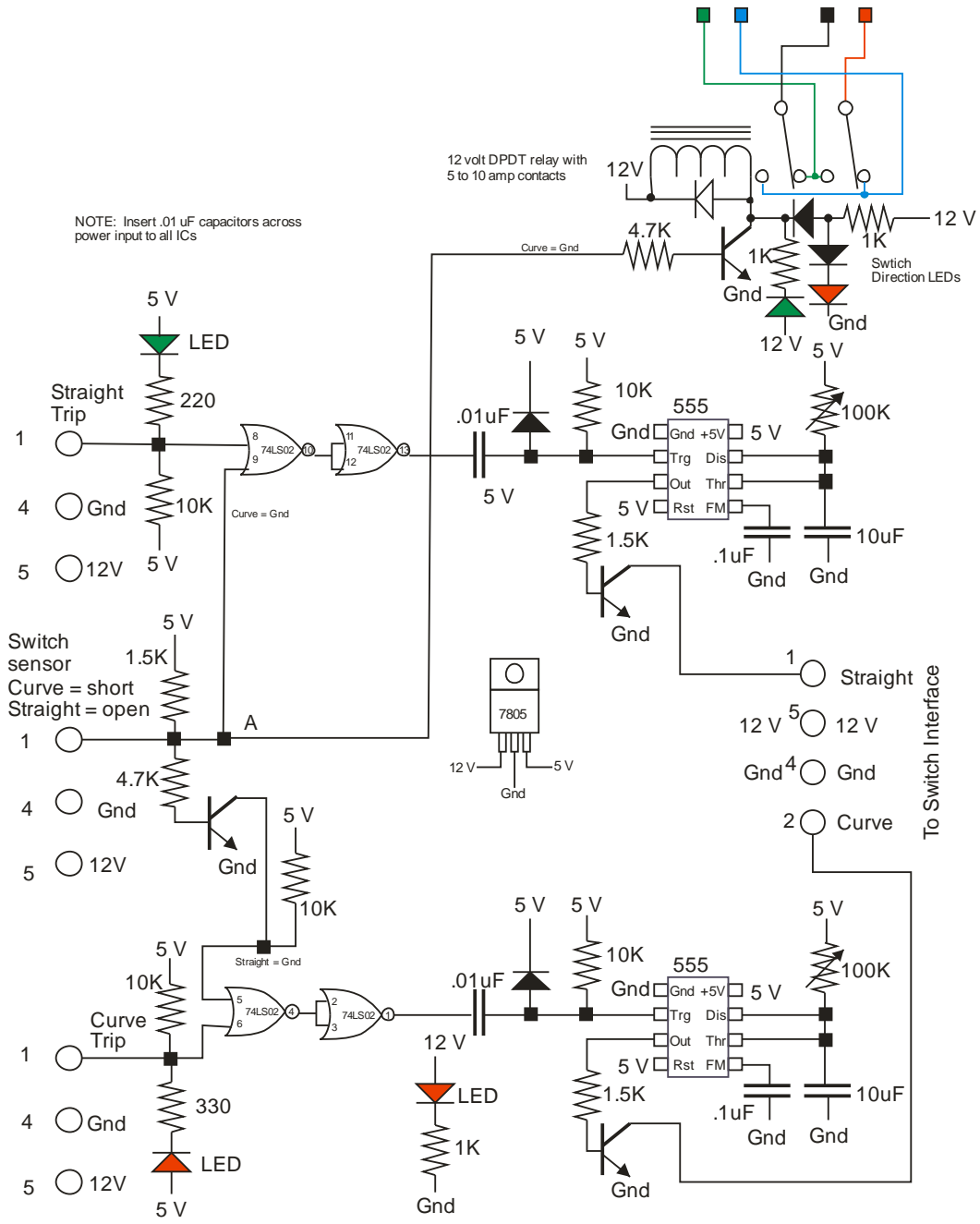
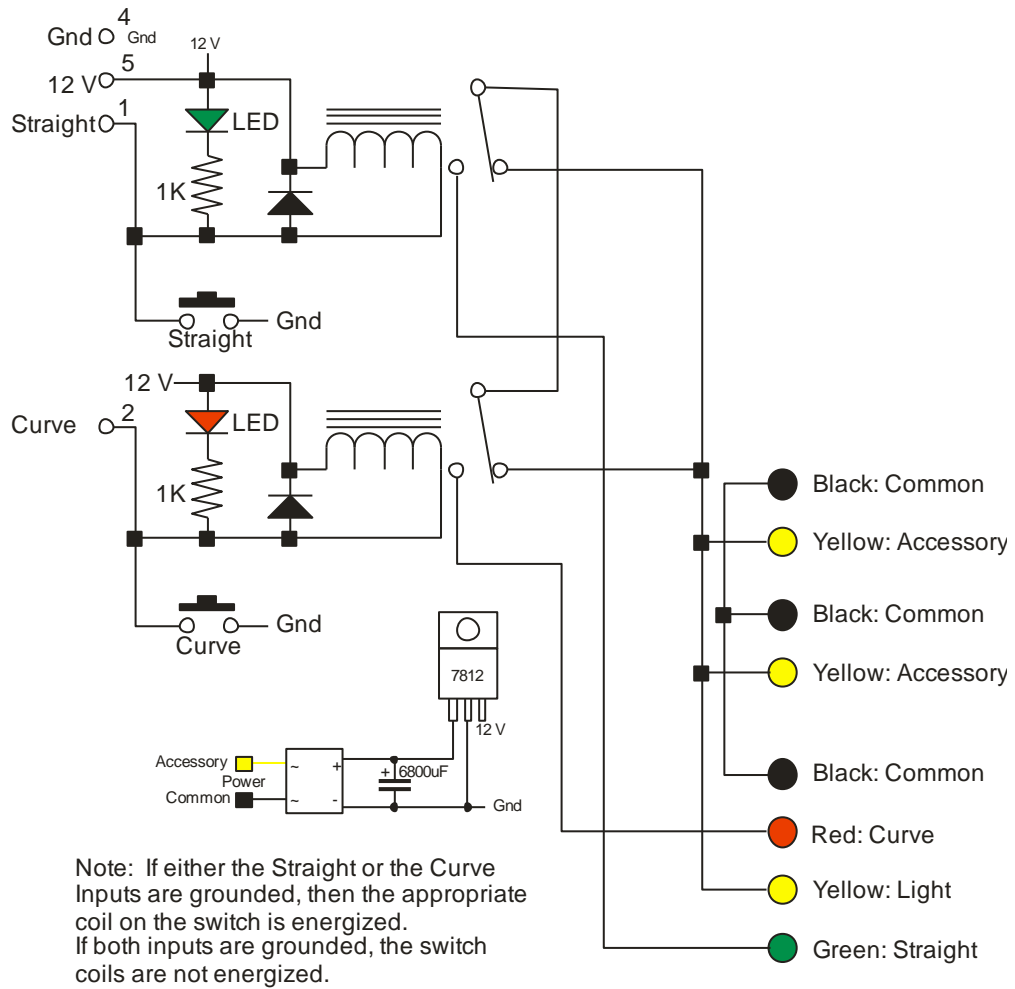

Figure 13: Reverse Loop Control Schematic (Part 1)



**Figure 14: Reverse Loop Control Schematic: Switch Interface (Part 2)**



## 4.2 DC Operation

Figure 15 illustrates how operation of a reverse loop can be fully automated with DC. The same circuits for the AC operation can be employed, but the location of the trips and the connections to the track are somewhat different. Note that Figure 15 addresses two reverse loops at the same time. Also note that only the upper track switch is sensed; the lower track switch is slaved off of the upper switch. If the direction of the lower switch is not the same as the upper switch, the train will stop upon entering the lower reverse loop.

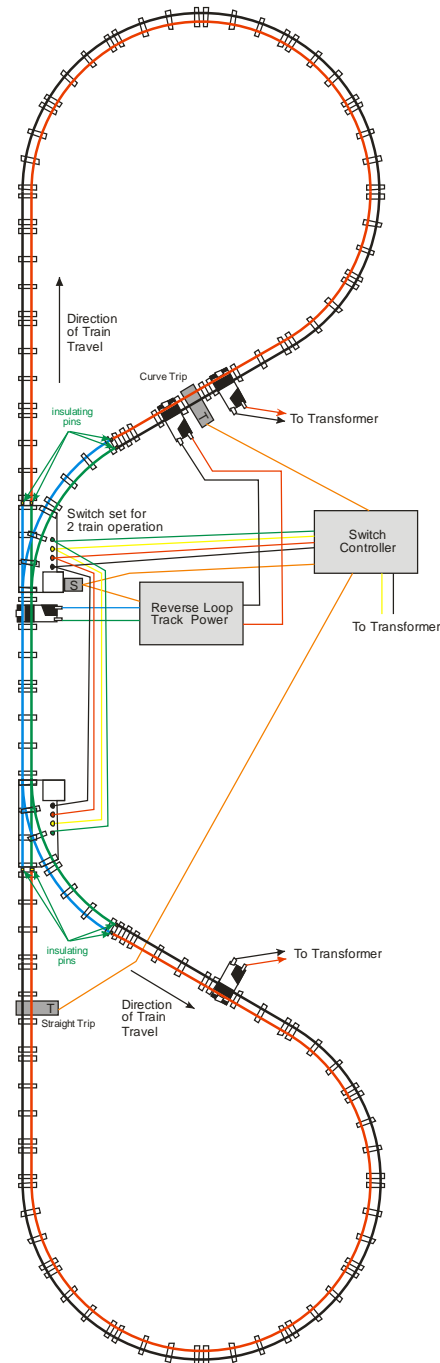
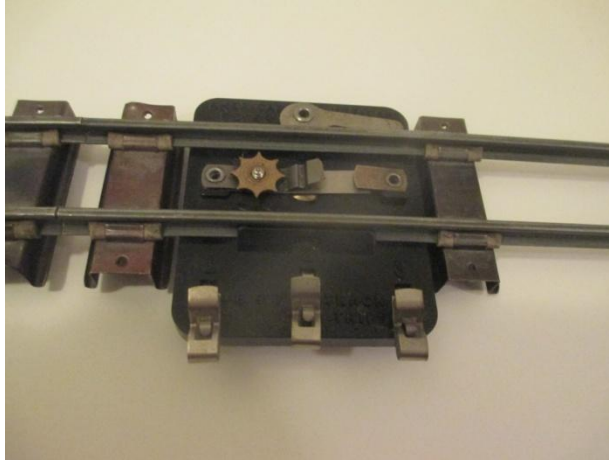

Figure 15: DC Operation Automatic Reverse Loop and Switch Control

(This page left intentionally blank)

## Appendix A: Track Trips

### A.1 Pressure Trips (AF 697)



**Figure 16: Pressure Track Trip #697**

The 697 pressure track trip is activated by weight. It can be adjusted to activate by the weight of the engine, or by the entire train. When the trip is not activated (no train present) the circuit is closed between contacts number 1 and 2 and contact 3 is disconnected. When activated the circuit is closed between contacts number 1 and 3 and contact 2 is disconnected.

The "star" wheel on the trip is used to adjust the activation weight. Turn the wheel counter-clockwise to reduce the pressure required to activate and turn the wheel clockwise to increase the pressure required to activate.

Because the contacts are electrically isolated from the rails, the 697 trip can be used to directly control the circuits in this document: use contacts 1 and 3.

If used on a layout, it is important not to solidly fasten the track for several sections on either side of the track trip; the track must be able to freely move up and down. This restriction may make the use of this trip on a layout not practical.

## A.2 "Shoe" Trips (AF 696)



Figure 17: Shoe Track Trip #696

The 696 shoe track trip is activated by the wheels of the engine and cars pressing down on the shoe. When the shoe is depressed, the circuit is closed between the one contact and the rail adjacent to the shoe.

If you are sure that the 12V supply for the control system is electrically isolated from the secondary of the transformer used to power the track, you can directly use the 696 trip by connecting the control circuit to the one contact on the 696 trip and to the rail adjacent to the shoe (using a 707 or 690 track terminal for example)

If you are not sure if the 12V supply will be electrically isolated from the secondary of the transformer used to power the track, you should use an isolation circuit. Figure 18 is an example of such an isolation circuit. The "Trip In" is connected to the 696 trip connection and to the track rail opposite from the shoe. This trip isolation circuit will only activate when there is voltage applied to the track and the shoe is depressed. It will work for either AC or DC operation.

Figure 19 shows how to make the track connections with and without the isolation circuit.

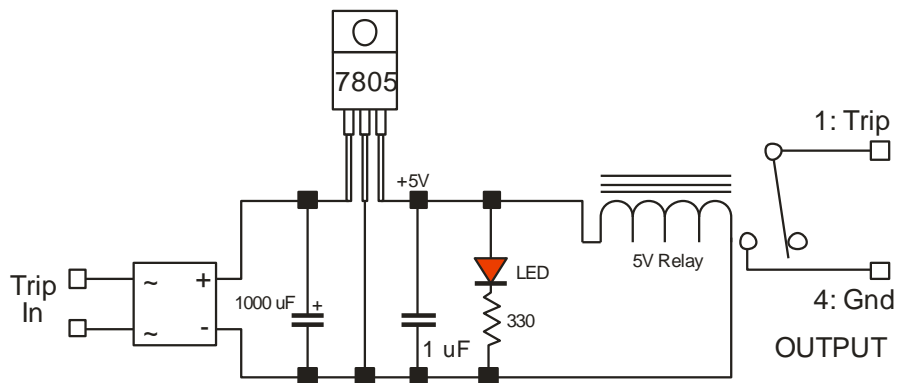
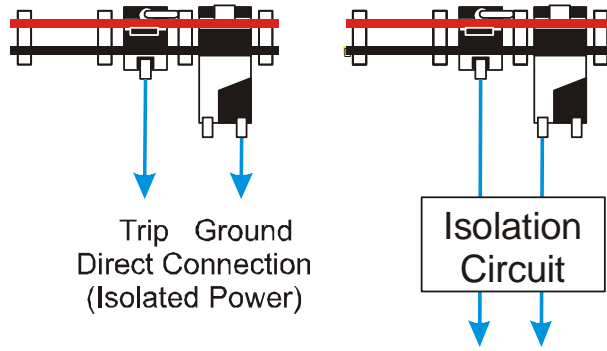

Figure 18: 696 Isolation Circuit



**Figure 19: Track Connection for 696 Track Trip**

One potential issue with the 696 trip is that for some steam locomotives, the pilot wheels are not heavy enough and tend to derail when they hit the shoe. This can usually be rectified by adding a lead weight to the pilot wheels.

### A.3 Current Trip: Electric Track Trip (AF 670)

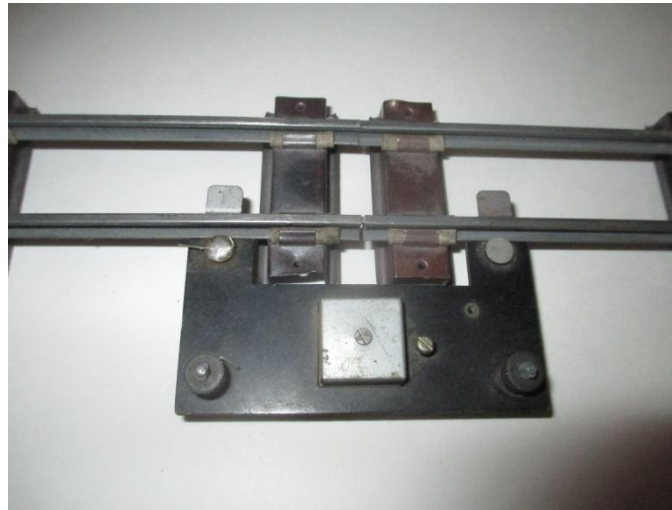

Figure 20: Electric Track Trip #670

Electric track trips work by connecting a relay in series with the train engine on a control section of track. The relay coil is designed to have a low voltage drop and be able to handle the current draw of an engine. The 670 electric track trip, shown in Figure 20 is an example of an electric track trip. As shown in Figure 21, the 670 electric track trip is connected in series with an isolated control section of track (between the insulating pins); when power is drawn from the control section of track, the relay closes the connection between the two terminal on the trip.

Because the contacts are electrically isolated from the rails, the 670 trip can be used to directly control the circuits in this document.

One issue I have experienced with these trips is that occasionally the contacts will stick. Some variants of this trip have an adjustment screw that can be used to improve reliability.

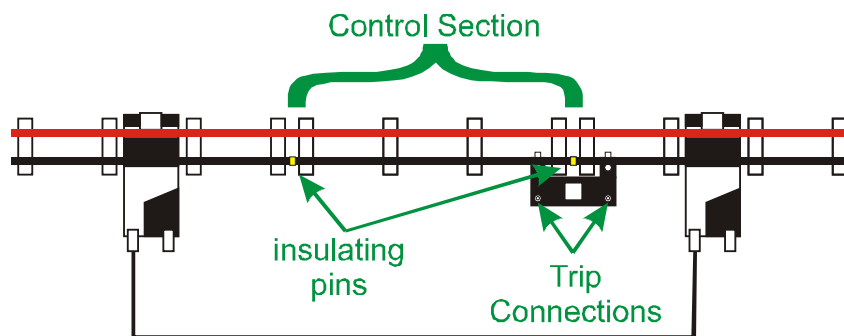

Figure 21: Using the #670 Electric Track Trip

The No. 26671, No. 26672, and No. 26673 Electric Track Trips operate in a similar way as the 670, however instead of having isolated contacts, these trips have only one contact which will connect to the rail not in the isolated control section. See Figure 22 and Figure 23 for the typical connection of the 26671 and 26672 electric track trips. Because the contact is not isolated from the rail, it must be treated

similar to the 696 trip above. If you are not sure if the 12V supply is isolated, the isolation circuit depicted in Figure 18 may be used.

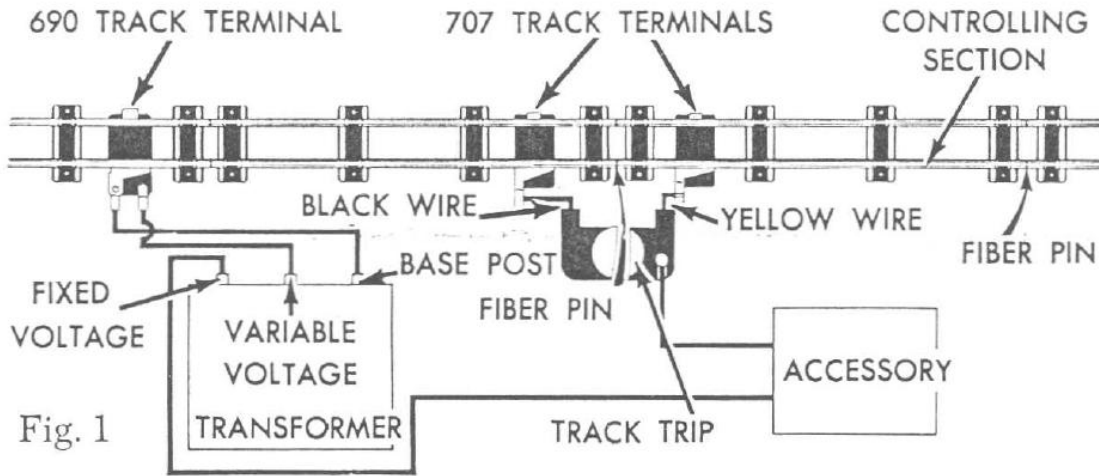

Figure 22: A.C. Gilbert instructions for no. 26671 Electric Track Trip

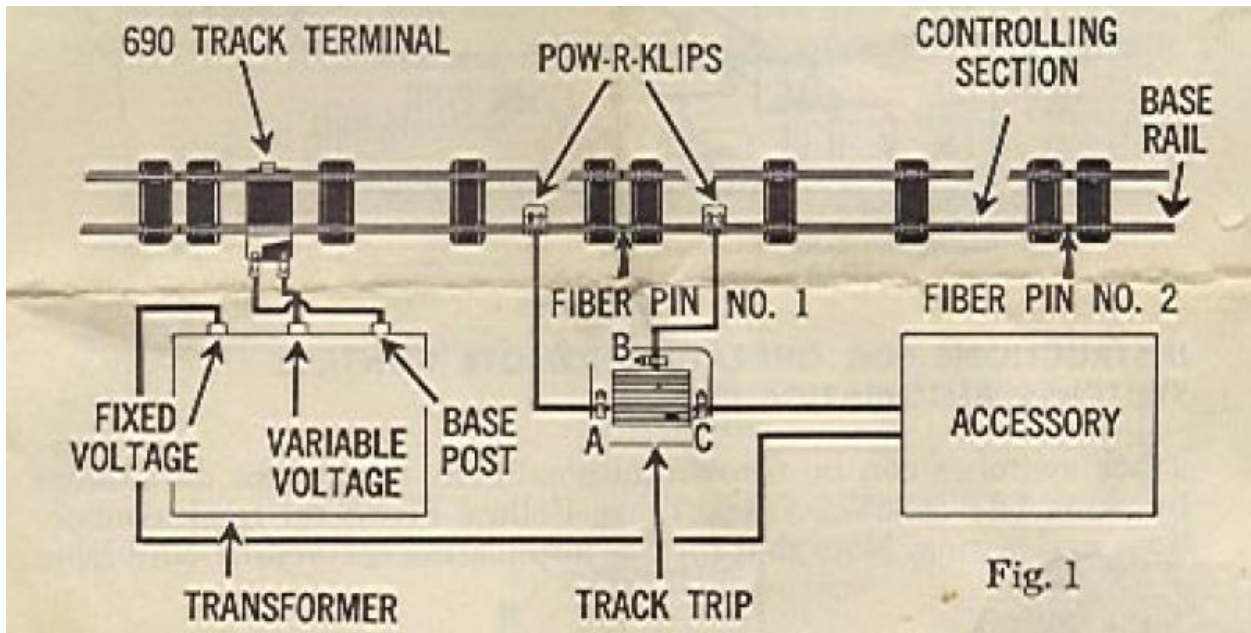
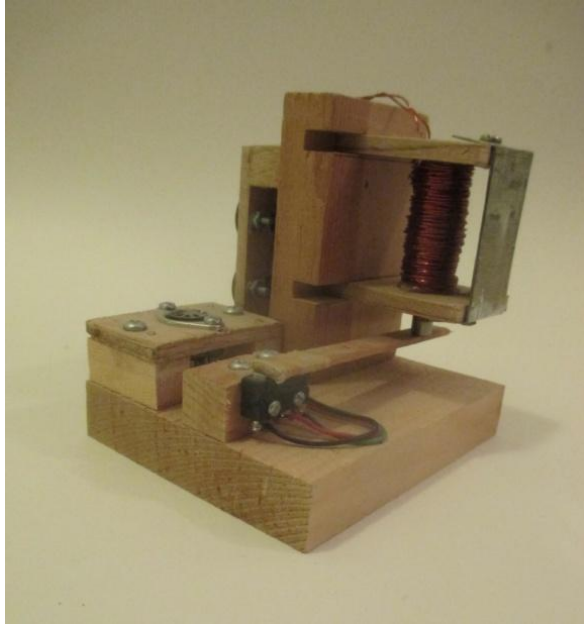

Figure 23: A.C. Gilbert Instructions for no. 26672 Electric Track Trip

Note that it is possible to make your own electric track trip. See Figure 24.



**Figure 24: Home-made electric track trip**





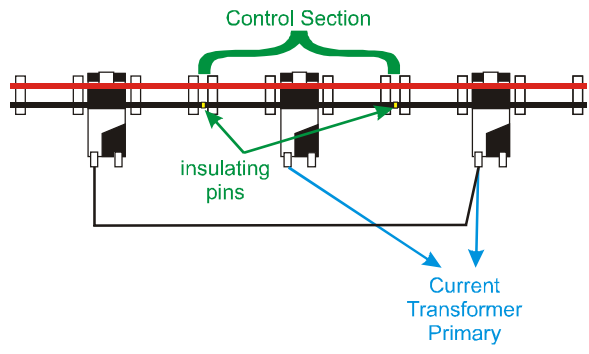

**Figure 27: Current Transformer Connection to Track**

## A.5 Infrared Trip: Reflective

A reflective IR track trip works by sensing infrared light reflected by a passing train. The infrared LED emitter can be co-located with the infrared sensor as shown in Figure 28 (Two components on the black plastic bases). The reflective IR track trip can be easily installed in a track-side building as shown in Figure 29. Alternately, such as on a permanent layout, the emitter and sensor can be installed underneath the track pointing up; the circuitry can be hidden under the roadbed.

When using reflective track trips, be wary of stray sunlight shining on the sensor; sunlight (and even some electric lights) can activate the sensor. You may have to experiment with shielding the sensor from stray light and keeping unintended objects from reflecting light back to the sensor.

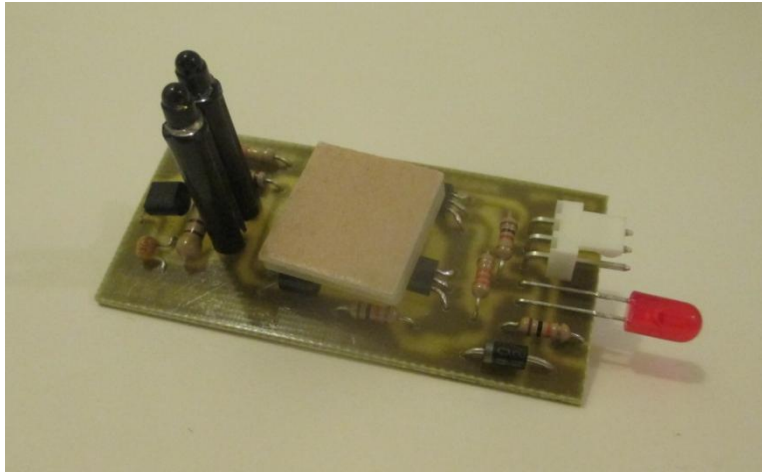

Figure 28: Reflective IR trip (Sensa-Trak II from TCH Technology)



Figure 29: Reflective IR trip installed in track-side building

## A.6 Infrared Trip: Beam Breaking

I have found the beam breaking IR track trip to be very reliable, second only to the electronic current sensor. Unlike the electronic current sensor, beam breaking IR track trips aren't sensitive to whether you operate your layout with AC or DC. This type of trip works by detecting when a beam of infrared light is interrupted. Since the location of the source of light is well known, the IR sensor can be easily shielded to only respond to the IR LED and not to stray light. Additionally, an IR sensor can be chosen that only responds to IR light that is pulsed at a given frequency, typically around 30 to 40 kHz. Steady sources of IR light, such as the sun, can be filtered out if there is sufficient shielding to avoid completely saturating the receiver. Figure 30 is an example of a beam breaking IR trip. The IR LED is in the black box to the right and the sensor is the silver box suspended from the roof of the building. The beam of IR light is diagonal across the track to ensure the beam is broken when a train passes, even between train cars. The circuit for the beam breaking IR track trip is shown in Figure 31.

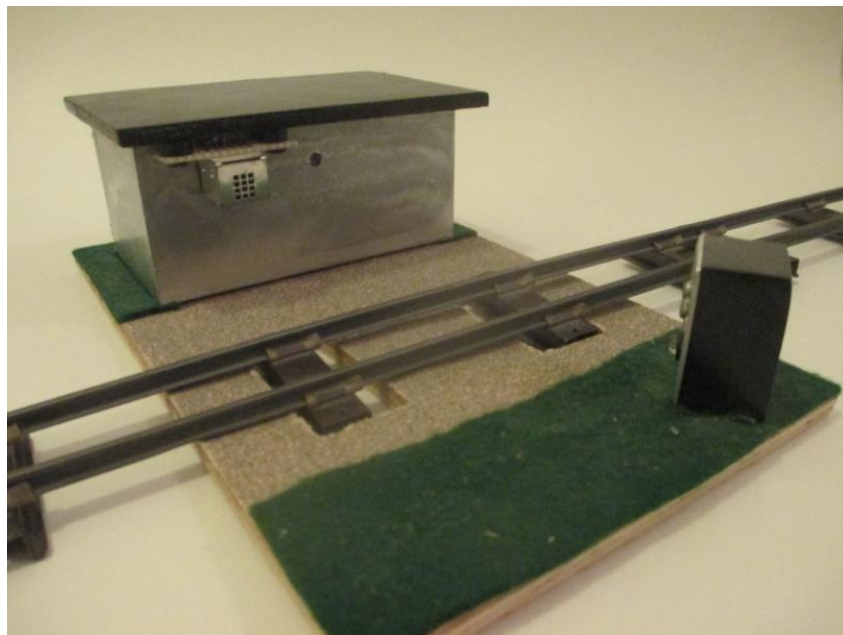

Figure 30: Beam Breaking IR Track Trip



(This page left intentionally blank)

## Appendix B: Track Switch Direction Sensor

Automating operation of the reverse loop requires a reliable signal for the direction of the reverse loop track switch. Sensing the direction of the switch can either be done directly or indirectly. With the indirect method, the position of the switch is determined by sensing which of the two track switch coils was last energized. This method does not require any modification to the remote control switches, but can provide an erroneous signal on power-up or if the track switch is manually changed. Indirect sensing can also be done at the location of the switch controller, and thus do not require running extra sensor wires to the actual track switch.

The direct sensors determine the actual position of the track switch, and thus provide a more reliable signal. The direct sensors do require a reversible modification to the track switch. I prefer using the direct sensors.

In sensing the direction of a switch with a single electrical signal, a convention must be established for relating the sensor output to a switch direction. For me personally, I am adopting the convention that the sensor output will be a "short" to ground when the switch is in the curved position, and a "open circuit" to ground when the switch is in the straight position.

### B.1 Indirect Sensing using Atlas Snap Relay

The Atlas Snap Relay can be used to indirectly sense the position of the track switch. One set of contacts can be used for the signal and the other set of contacts can be used for LEDs to indicate the direction sensed.

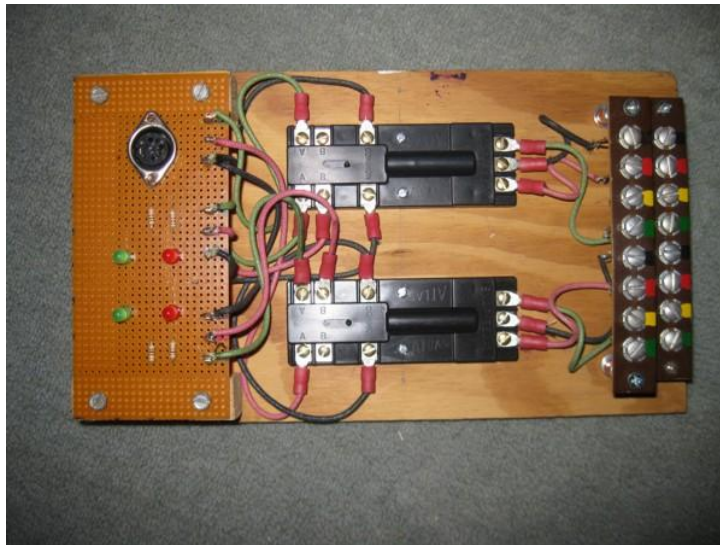

Figure 32: Example of Atlas Snap Relays used for Switch Direction Sensing

## B.2 Indirect Sensing using Opto-Isolators

Another method of indirectly sensing a track switch direction is to detect when one of the two lamps of the switch remote controller is on. Figure 33 is an example of such an indirect sensor. Figure 34 is the schematic diagram. The circuit connects to the light socket of the red light bulb of the controller. When the red light is on, the LED in the opto-isolator is also energized, thereby turning the output transistor on.



Figure 33: Example of opto-isolators used for Switch Direction Sensing

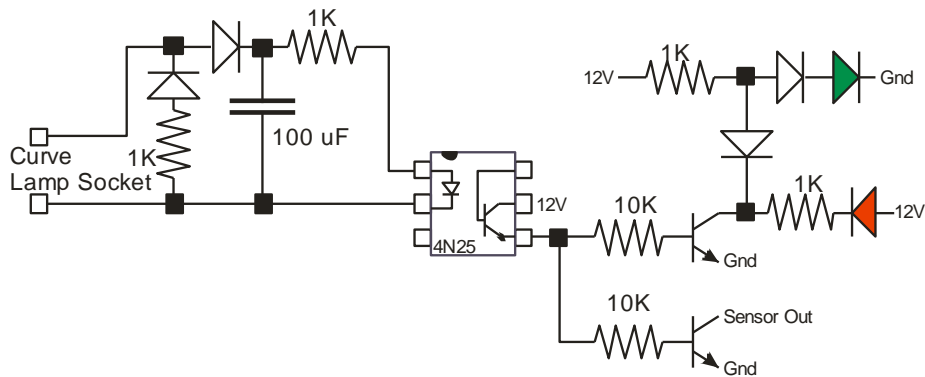

Figure 34: Schematic for opto-isolator indirect Switch Direction Sensing

This sensor may be inaccurate if the operator only pushes the switch lever far enough to activate the curved switch coil, and not far enough to energize the red light.



### **B.3 Direct Sensing using reed switch**

A reed switch (Figure 35) is a very simple electromechanical device consisting of two metal reeds inside a glass tube. For a normally open reed switch, the two reeds are not in contact normally. When a magnet is placed next to the reed switch, the magnet attracts both reeds, causing both to bend and make contact. Hence the reed switch can detect the presence of a magnet.

As shown in Figure 36, it is possible to glue (I use hot melt glue) a reed switch inside the housing of an American Flyer Switch and attach a small, but strong magnet on the shutter mechanism for the light. When the shutter is in the "curved" direction, the magnet is close enough to the reed switch for it to complete the circuit. The wires for the reed switch can be routed through the bottom of the switch.

Radio Shack sells small (3/16 inch) "Rare Earth Super Magnets" which work well in this application.

Getting a reliable orientation and position for both the reed switch and the magnet may take some experimentation. I have found that once reliable operation is achieved, this method works well and I have not had to readjust the reed switch or magnet when placed in operation.



**Figure 35: Magnetic Reed Switch**



**Figure 36: Example of magnetic reed switch used for Switch Direction Sensing**

#### B.4 Direct Sensing using hall effect sensor

A hall effect sensor is essentially a solid-state replacement for a reed switch. It does require three wires: Two for power and one for the signal. I have found that it is much easier to get reliable operation with these sensors as compared to reed switches. I use a Cherry Corporation MP101301 (Figure 37), available from Jameco Electronics. The 3/16 inch "Rare Earth Super Magnets" from Radio Shack work well. An example of direct sensing using a hall effect sensor is shown in Figure 38.

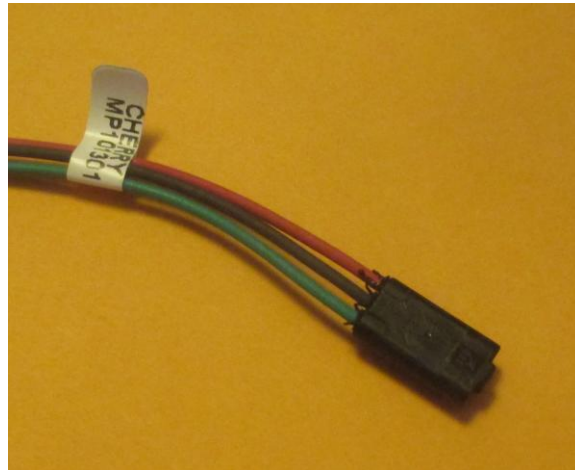

Figure 37: Hall Effect Sensor (MP101301)



Figure 38: Example of hall effect sensor used for Switch Direction Sensing

# Appendix C: GNU Free Documentation License

Version 1.3, 3 November 2008

Copyright © 2000, 2001, 2002, 2007, 2008 Free Software Foundation, Inc. <<http://fsf.org/>>

Everyone is permitted to copy and distribute verbatim copies of this license document, but changing it is not allowed.

## 0. PREAMBLE

The purpose of this License is to make a manual, textbook, or other functional and useful document "free" in the sense of freedom: to assure everyone the effective freedom to copy and redistribute it, with or without modifying it, either commercially or noncommercially. Secondly, this License preserves for the author and publisher a way to get credit for their work, while not being considered responsible for modifications made by others.

This License is a kind of "copyleft", which means that derivative works of the document must themselves be free in the same sense. It complements the GNU General Public License, which is a copyleft license designed for free software.

We have designed this License in order to use it for manuals for free software, because free software needs free documentation: a free program should come with manuals providing the same freedoms that the software does. But this License is not limited to software manuals; it can be used for any textual work, regardless of subject matter or whether it is published as a printed book. We recommend this License principally for works whose purpose is instruction or reference.

## 1. APPLICABILITY AND DEFINITIONS

This License applies to any manual or other work, in any medium, that contains a notice placed by the copyright holder saying it can be distributed under the terms of this License. Such a notice grants a world-wide, royalty-free license, unlimited in duration, to use that work under the conditions stated herein. The "Document", below, refers to any such manual or work. Any member of the public is a licensee, and is addressed as "you". You accept the license if you copy, modify or distribute the work in a way requiring permission under copyright law.

A "Modified Version" of the Document means any work containing the Document or a portion of it, either copied verbatim, or with modifications and/or translated into another language.

A "Secondary Section" is a named appendix or a front-matter section of the Document that deals exclusively with the relationship of the publishers or authors of the Document to the Document's overall subject (or to related matters) and contains nothing that could fall directly within that overall subject. (Thus, if the Document is in part a textbook of mathematics, a Secondary Section may not explain any mathematics.) The relationship could be a matter of historical connection with the subject or with related matters, or of legal, commercial, philosophical, ethical or political position regarding them.

The "Invariant Sections" are certain Secondary Sections whose titles are designated, as being those of Invariant Sections, in the notice that says that the Document is released under this License. If a section does not fit the above definition of Secondary then it is not allowed to be designated as Invariant. The Document may contain zero Invariant Sections. If the Document does not identify any Invariant Sections then there are none.

The "Cover Texts" are certain short passages of text that are listed, as Front-Cover Texts or Back-Cover Texts, in the notice that says that the Document is released under this License. A Front-Cover Text may be at most 5 words, and a Back-Cover Text may be at most 25 words.

A "Transparent" copy of the Document means a machine-readable copy, represented in a format whose specification is available to the general public, that is suitable for revising the document straightforwardly with generic text editors or (for images composed of pixels) generic paint programs or (for drawings) some widely available drawing editor, and that is suitable for input to text formatters or for automatic translation to a variety of formats suitable for input to text formatters. A copy made in an otherwise Transparent file format whose markup, or absence of markup, has been arranged to thwart or discourage subsequent

modification by readers is not Transparent. An image format is not Transparent if used for any substantial amount of text. A copy that is not "Transparent" is called "Opaque".

Examples of suitable formats for Transparent copies include plain ASCII without markup, Texinfo input format, LaTeX input format, SGML or XML using a publicly available DTD, and standard-conforming simple HTML, PostScript or PDF designed for human modification. Examples of transparent image formats include PNG, XCF and JPG. Opaque formats include proprietary formats that can be read and edited only by proprietary word processors, SGML or XML for which the DTD and/or processing tools are not generally available, and the machine-generated HTML, PostScript or PDF produced by some word processors for output purposes only.

The "Title Page" means, for a printed book, the title page itself, plus such following pages as are needed to hold, legibly, the material this License requires to appear in the title page. For works in formats which do not have any title page as such, "Title Page" means the text near the most prominent appearance of the work's title, preceding the beginning of the body of the text.

The "publisher" means any person or entity that distributes copies of the Document to the public.

A section "Entitled XYZ" means a named subunit of the Document whose title either is precisely XYZ or contains XYZ in parentheses following text that translates XYZ in another language. (Here XYZ stands for a specific section name mentioned below, such as "Acknowledgements", "Dedications", "Endorsements", or "History".) To "Preserve the Title" of such a section when you modify the Document means that it remains a section "Entitled XYZ" according to this definition.

The Document may include Warranty Disclaimers next to the notice which states that this License applies to the Document. These Warranty Disclaimers are considered to be included by reference in this License, but only as regards disclaiming warranties: any other implication that these Warranty Disclaimers may have is void and has no effect on the meaning of this License.

## **2. VERBATIM COPYING**

You may copy and distribute the Document in any medium, either commercially or noncommercially, provided that this License, the copyright notices, and the license notice saying this License applies to the Document are reproduced in all copies, and that you add no other conditions whatsoever to those of this License. You may not use technical measures to obstruct or control the reading or further copying of the copies you make or distribute. However, you may accept compensation in exchange for copies. If you distribute a large enough number of copies you must also follow the conditions in section 3.

You may also lend copies, under the same conditions stated above, and you may publicly display copies.

## **3. COPYING IN QUANTITY**

If you publish printed copies (or copies in media that commonly have printed covers) of the Document, numbering more than 100, and the Document's license notice requires Cover Texts, you must enclose the copies in covers that carry, clearly and legibly, all these Cover Texts: Front-Cover Texts on the front cover, and Back-Cover Texts on the back cover. Both covers must also clearly and legibly identify you as the publisher of these copies. The front cover must present the full title with all words of the title equally prominent and visible. You may add other material on the covers in addition. Copying with changes limited to the covers, as long as they preserve the title of the Document and satisfy these conditions, can be treated as verbatim copying in other respects.

If the required texts for either cover are too voluminous to fit legibly, you should put the first ones listed (as many as fit reasonably) on the actual cover, and continue the rest onto adjacent pages.

If you publish or distribute Opaque copies of the Document numbering more than 100, you must either include a machine-readable Transparent copy along with each Opaque copy, or state in or with each Opaque copy a computer-network location from which the general network-using public has access to download using public-standard network protocols a complete Transparent copy of the Document, free of added material. If you use the latter option, you must take reasonably prudent steps, when you begin distribution of Opaque copies in quantity, to ensure that this Transparent copy will remain thus accessible at the stated location until at least one year after the last time you distribute an Opaque copy (directly or through your agents or retailers) of that edition to the public.

It is requested, but not required, that you contact the authors of the Document well before redistributing any large number of copies, to give them a chance to provide you with an updated version of the Document.

#### 4. MODIFICATIONS

You may copy and distribute a Modified Version of the Document under the conditions of sections 2 and 3 above, provided that you release the Modified Version under precisely this License, with the Modified Version filling the role of the Document, thus licensing distribution and modification of the Modified Version to whoever possesses a copy of it. In addition, you must do these things in the Modified Version:

- A. Use in the Title Page (and on the covers, if any) a title distinct from that of the Document, and from those of previous versions (which should, if there were any, be listed in the History section of the Document). You may use the same title as a previous version if the original publisher of that version gives permission.
- B. List on the Title Page, as authors, one or more persons or entities responsible for authorship of the modifications in the Modified Version, together with at least five of the principal authors of the Document (all of its principal authors, if it has fewer than five), unless they release you from this requirement.
- C. State on the Title page the name of the publisher of the Modified Version, as the publisher.
- D. Preserve all the copyright notices of the Document.
- E. Add an appropriate copyright notice for your modifications adjacent to the other copyright notices.
- F. Include, immediately after the copyright notices, a license notice giving the public permission to use the Modified Version under the terms of this License, in the form shown in the Addendum below.
- G. Preserve in that license notice the full lists of Invariant Sections and required Cover Texts given in the Document's license notice.
- H. Include an unaltered copy of this License.
- I. Preserve the section Entitled "History", Preserve its Title, and add to it an item stating at least the title, year, new authors, and publisher of the Modified Version as given on the Title Page. If there is no section Entitled "History" in the Document, create one stating the title, year, authors, and publisher of the Document as given on its Title Page, then add an item describing the Modified Version as stated in the previous sentence.
- J. Preserve the network location, if any, given in the Document for public access to a Transparent copy of the Document, and likewise the network locations given in the Document for previous versions it was based on. These may be placed in the "History" section. You may omit a network location for a work that was published at least four years before the Document itself, or if the original publisher of the version it refers to gives permission.
- K. For any section Entitled "Acknowledgements" or "Dedications", Preserve the Title of the section, and preserve in the section all the substance and tone of each of the contributor acknowledgements and/or dedications given therein.
- L. Preserve all the Invariant Sections of the Document, unaltered in their text and in their titles. Section numbers or the equivalent are not considered part of the section titles.
- M. Delete any section Entitled "Endorsements". Such a section may not be included in the Modified Version.
- N. Do not retitle any existing section to be Entitled "Endorsements" or to conflict in title with any Invariant Section.
- O. Preserve any Warranty Disclaimers.

If the Modified Version includes new front-matter sections or appendices that qualify as Secondary Sections and contain no material copied from the Document, you may at your option designate some or all of these sections as invariant. To do this, add their titles to the list of Invariant Sections in the Modified Version's license notice. These titles must be distinct from any other section titles.

You may add a section Entitled "Endorsements", provided it contains nothing but endorsements of your Modified Version by various parties—for example, statements of peer review or that the text has been approved by an organization as the authoritative definition of a standard.

You may add a passage of up to five words as a Front-Cover Text, and a passage of up to 25 words as a Back-Cover Text, to the end of the list of Cover Texts in the Modified Version. Only one passage of Front-Cover Text and one of Back-Cover Text may be added by (or through arrangements made by) any one entity. If the Document already includes a cover text for the same cover, previously added by you or by arrangement made by the same entity you are acting on behalf of, you may not add another; but you may replace the old one, on explicit permission from the previous publisher that added the old one.

The author(s) and publisher(s) of the Document do not by this License give permission to use their names for publicity for or to assert or imply endorsement of any Modified Version.

## ***5. COMBINING DOCUMENTS***

You may combine the Document with other documents released under this License, under the terms defined in section 4 above for modified versions, provided that you include in the combination all of the Invariant Sections of all of the original documents, unmodified, and list them all as Invariant Sections of your combined work in its license notice, and that you preserve all their Warranty Disclaimers.

The combined work need only contain one copy of this License, and multiple identical Invariant Sections may be replaced with a single copy. If there are multiple Invariant Sections with the same name but different contents, make the title of each such section unique by adding at the end of it, in parentheses, the name of the original author or publisher of that section if known, or else a unique number. Make the same adjustment to the section titles in the list of Invariant Sections in the license notice of the combined work.

In the combination, you must combine any sections Entitled "History" in the various original documents, forming one section Entitled "History"; likewise combine any sections Entitled "Acknowledgements", and any sections Entitled "Dedications". You must delete all sections Entitled "Endorsements".

## ***6. COLLECTIONS OF DOCUMENTS***

You may make a collection consisting of the Document and other documents released under this License, and replace the individual copies of this License in the various documents with a single copy that is included in the collection, provided that you follow the rules of this License for verbatim copying of each of the documents in all other respects.

You may extract a single document from such a collection, and distribute it individually under this License, provided you insert a copy of this License into the extracted document, and follow this License in all other respects regarding verbatim copying of that document.

## ***7. AGGREGATION WITH INDEPENDENT WORKS***

A compilation of the Document or its derivatives with other separate and independent documents or works, in or on a volume of a storage or distribution medium, is called an "aggregate" if the copyright resulting from the compilation is not used to limit the legal rights of the compilation's users beyond what the individual works permit. When the Document is included in an aggregate, this License does not apply to the other works in the aggregate which are not themselves derivative works of the Document.

If the Cover Text requirement of section 3 is applicable to these copies of the Document, then if the Document is less than one half of the entire aggregate, the Document's Cover Texts may be placed on covers that bracket the Document within the aggregate, or the electronic equivalent of covers if the Document is in electronic form. Otherwise they must appear on printed covers that bracket the whole aggregate.

## ***8. TRANSLATION***

Translation is considered a kind of modification, so you may distribute translations of the Document under the terms of section 4. Replacing Invariant Sections with translations requires special permission from their copyright holders, but you may include translations of some or all Invariant Sections in addition to the original versions of these Invariant Sections. You may include a translation of this License, and all the license notices in the Document, and any Warranty Disclaimers, provided that you also include the original English version of this License and the original versions of those notices and disclaimers. In case of a disagreement between the translation and the original version of this License or a notice or disclaimer, the original version will prevail.

If a section in the Document is Entitled "Acknowledgements", "Dedications", or "History", the requirement (section 4) to Preserve its Title (section 1) will typically require changing the actual title.

## 9. TERMINATION

You may not copy, modify, sublicense, or distribute the Document except as expressly provided under this License. Any attempt otherwise to copy, modify, sublicense, or distribute it is void, and will automatically terminate your rights under this License.

However, if you cease all violation of this License, then your license from a particular copyright holder is reinstated (a) provisionally, unless and until the copyright holder explicitly and finally terminates your license, and (b) permanently, if the copyright holder fails to notify you of the violation by some reasonable means prior to 60 days after the cessation.

Moreover, your license from a particular copyright holder is reinstated permanently if the copyright holder notifies you of the violation by some reasonable means, this is the first time you have received notice of violation of this License (for any work) from that copyright holder, and you cure the violation prior to 30 days after your receipt of the notice.

Termination of your rights under this section does not terminate the licenses of parties who have received copies or rights from you under this License. If your rights have been terminated and not permanently reinstated, receipt of a copy of some or all of the same material does not give you any rights to use it.

## 10. FUTURE REVISIONS OF THIS LICENSE

The Free Software Foundation may publish new, revised versions of the GNU Free Documentation License from time to time. Such new versions will be similar in spirit to the present version, but may differ in detail to address new problems or concerns. See <http://www.gnu.org/copyleft/>.

Each version of the License is given a distinguishing version number. If the Document specifies that a particular numbered version of this License "or any later version" applies to it, you have the option of following the terms and conditions either of that specified version or of any later version that has been published (not as a draft) by the Free Software Foundation. If the Document does not specify a version number of this License, you may choose any version ever published (not as a draft) by the Free Software Foundation. If the Document specifies that a proxy can decide which future versions of this License can be used, that proxy's public statement of acceptance of a version permanently authorizes you to choose that version for the Document.

## 11. RELICENSING

"Massive Multiauthor Collaboration Site" (or "MMC Site") means any World Wide Web server that publishes copyrightable works and also provides prominent facilities for anybody to edit those works. A public wiki that anybody can edit is an example of such a server. A "Massive Multiauthor Collaboration" (or "MMC") contained in the site means any set of copyrightable works thus published on the MMC site.

"CC-BY-SA" means the Creative Commons Attribution-Share Alike 3.0 license published by Creative Commons Corporation, a not-for-profit corporation with a principal place of business in San Francisco, California, as well as future copyleft versions of that license published by that same organization.

"Incorporate" means to publish or republish a Document, in whole or in part, as part of another Document.

An MMC is "eligible for relicensing" if it is licensed under this License, and if all works that were first published under this License somewhere other than this MMC, and subsequently incorporated in whole or in part into the MMC, (1) had no cover texts or invariant sections, and (2) were thus incorporated prior to November 1, 2008.

The operator of an MMC Site may republish an MMC contained in the site under CC-BY-SA on the same site at any time before August 1, 2009, provided the MMC is eligible for relicensing.