

NEXT GENERATION INTEGRATED POWER SYSTEM NGIPS Technology Development Roadmap

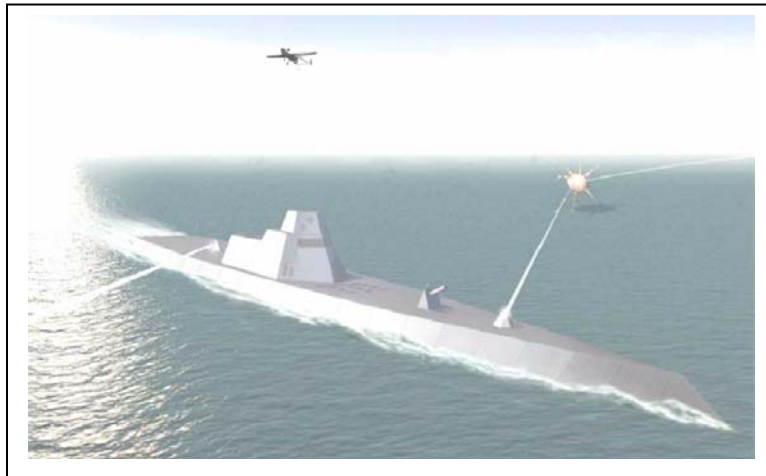

APPROVED FOR PUBLIC RELEASE

(This Page Left Intentionally Blank)

NEXT GENERATION INTEGRATED POWER SYSTEM
NGIPS Technology Development
Roadmap

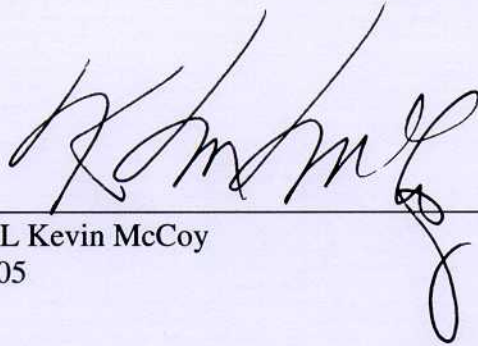

3 Dec 2007

RDML Kevin McCoy
SEA 05

(This Page Left Intentionally Blank)

REPORT DOCUMENTATION PAGE

Form Approved
OMB No. 0704-0188

Public reporting burden for this collection of information is estimated to average 1 hour per response, including the time for reviewing instructions, searching existing data sources, gathering and maintaining the data needed, and completing and reviewing this collection of information. Send comments regarding this burden estimate or any other aspect of this collection of information, including suggestions for reducing this burden to Department of Defense, Washington Headquarters Services, Directorate for Information Operations and Reports (0704-0188), 1215 Jefferson Davis Highway, Suite 1204, Arlington, VA 22202-4302. Respondents should be aware that notwithstanding any other provision of law, no person shall be subject to any penalty for failing to comply with a collection of information if it does not display a currently valid OMB control number. **PLEASE DO NOT RETURN YOUR FORM TO THE ABOVE ADDRESS.**

1. REPORT DATE (DD-MM-YYYY) 11-30-2007		2. REPORT TYPE FINAL		3. DATES COVERED (From - To) 01-01-2007 to 11-30-2007	
4. TITLE AND SUBTITLE Next Generation Integrated Power System NGIPS Technology Development Roadmap				5a. CONTRACT NUMBER	
				5b. GRANT NUMBER	
				5c. PROGRAM ELEMENT NUMBER	
6. AUTHOR(S) Norbert Doerry				5d. PROJECT NUMBER	
				5e. TASK NUMBER	
				5f. WORK UNIT NUMBER	
7. PERFORMING ORGANIZATION NAME(S) AND ADDRESS(ES) Naval Sea Systems Command 1333 Isaac Hull Ave SE Washington Navy Yard DC 20376				8. PERFORMING ORGANIZATION REPORT NUMBER	
9. SPONSORING / MONITORING AGENCY NAME(S) AND ADDRESS(ES)				10. SPONSOR/MONITOR'S ACRONYM(S)	
				11. SPONSOR/MONITOR'S REPORT NUMBER(S)	
12. DISTRIBUTION / AVAILABILITY STATEMENT Distribution Statement A: Approved for Public Release, Distribution is unlimited.					
13. SUPPLEMENTARY NOTES					
14. ABSTRACT The need for integrated power systems will increase in the coming decades with the increased projected propulsion and ship service power demands for future combatants with advanced sensors and weapons such as railguns and lasers. Integrated propulsion systems will also benefit the signature performance of future submarine classes. For expeditionary warfare ships, combat logistics ships, Maritime Prepositioning Force – Future (MPF(Future)), and support vessels, reduced fuel costs and overall reductions in life cycle cost will continue to drive to integrated power solutions. To meet the need of future ship designs, the Navy is investing in Next Generation Integrated Power (NGIPS) system technology. Additionally, to promote commonality and acquisition efficiency, the Navy plans to implement NGIPS using an Open Architecture Business and Technical model. The four technical architectures are: Medium Volt AC Power Generation (MVAC), High Frequency AC Power Generation (HFAC), Medium Voltage DC Power Generation (MVDC) Zonal Electrical Distribution Systems (ZEDS)					
15. SUBJECT TERMS Ship Electrical Power, Ship Propulsion, Open Architecture					
16. SECURITY CLASSIFICATION OF:			17. LIMITATION OF ABSTRACT	18. NUMBER OF PAGES 120	19a. NAME OF RESPONSIBLE PERSON Norbert Doerry
a. REPORT UNCLAS	b. ABSTRACT UNCLAS	c. THIS PAGE UNCLAS			19b. TELEPHONE NUMBER (include area code) (202) 781-2520

(This Page Left Intentionally Blank)

EXECUTIVE SUMMARY

By accomplishing the integrated tasks listed in this Next Generation Integrated Power System (NGIPS) Technology Development Roadmap, the Navy will be ready to produce affordable power solutions for future surface combatants, submarines, expeditionary warfare ships, combat logistic ships, maritime prepositioning force ships, and support vessels. This Technology Development Roadmap and the establishment of the Electric Ship Office (ESO) form the basis of the NGIPS strategy. NGIPS is an enterprise approach to develop and provide smaller, simpler, more affordable, and more capable power systems for all Navy ships. Managed by the ESO, NGIPS will define open architectures, develop common components, and coordinate Navy and industry investments.

The NGIPS enterprise approach will improve the power density and affordability of Navy power systems and deploy appropriate architectures, systems, and components as they are ready into ship acquisition programs. The NGIPS technical approach utilizes common elements such as Zonal Electrical Distribution Systems (ZEDS), power conversion modules, and electric power control modules as enablers along an evolutionary development path. The focal point for NGIPS is the cross platform ESO which is staffed by each of the stakeholders and has oversight and guidance from a flag level steering board. The private sector (Industry, academia and non-profits) is expected to participate in establishing / maintaining standards as well as developing technology aligned with this roadmap.

Anticipating increasing electric load requirements for combatants, the Navy's primary challenge is incorporating into future combatants medium voltage DC (MVDC) power generation with ZEDS. The need for integrated power systems will increase in the coming decades with the increased projected propulsion and ship service power demands for future combatants armed with advanced sensors and future weapons such as railguns and lasers. Integrated propulsion systems are also projected to benefit the signature performance of future submarine classes. For expeditionary warfare ships, combat logistics ships, Maritime Prepositioning Force – Future (MPF(Future)), and support vessels, reduced fuel costs and life cycle costs will continue to drive to integrated power solutions.

NGIPS will meet the power and affordability needs of our future fleet. NGIPS is both a business and technical approach to define standards and interfaces, increase commonality among combatants (surface and subsurface), and efficiently use installed power. To promote commonality and acquisition efficiency, NGIPS implements an Open Architecture (OA) Business and Technical model. The NGIPS OA Business Model segregates the tasks of determining required capabilities, ship system engineering, architecting, module development, systems integration, and life cycle support. The NGIPS Technical Architecture includes a set of standards for ZEDS as well as power generation and distribution. As shown in Figure 1, the Technical Architecture will implement MVDC standards as early in the Navy's procurement schedule as feasible. In the interim, the NGIPS Technical Architecture includes other standards for power generation and distribution: Medium Volt AC Power Generation (MVAC) and High Frequency AC Power Generation (HFAC).

Industry and the Navy must address a number of technical challenges to implement MVDC on surface combatants and submarines (naval warships requiring high power density). As a risk reduction step towards the MVDC system, a HFAC system is a potential alternative for near term new design submarines and surface combatants provided the solution is consistent with future MVDC systems. For amphibious warfare and auxiliary ships not requiring high power density, the MVAC systems will for the foreseeable future provide the most affordable solution for power generation and ship-wide distribution. Continuing investment in ZEDS is needed to assure affordable solution for all ships.

This roadmap includes a number of technology developments needed to implement the power generation architectures, improve affordability, and implement the OA Business and Technical Models. Overarching all technical advances, developing and maintaining standards, design data sheets, design tools, and design data are crucial to achieving the benefits of an open architecture and commonality across the fleet.

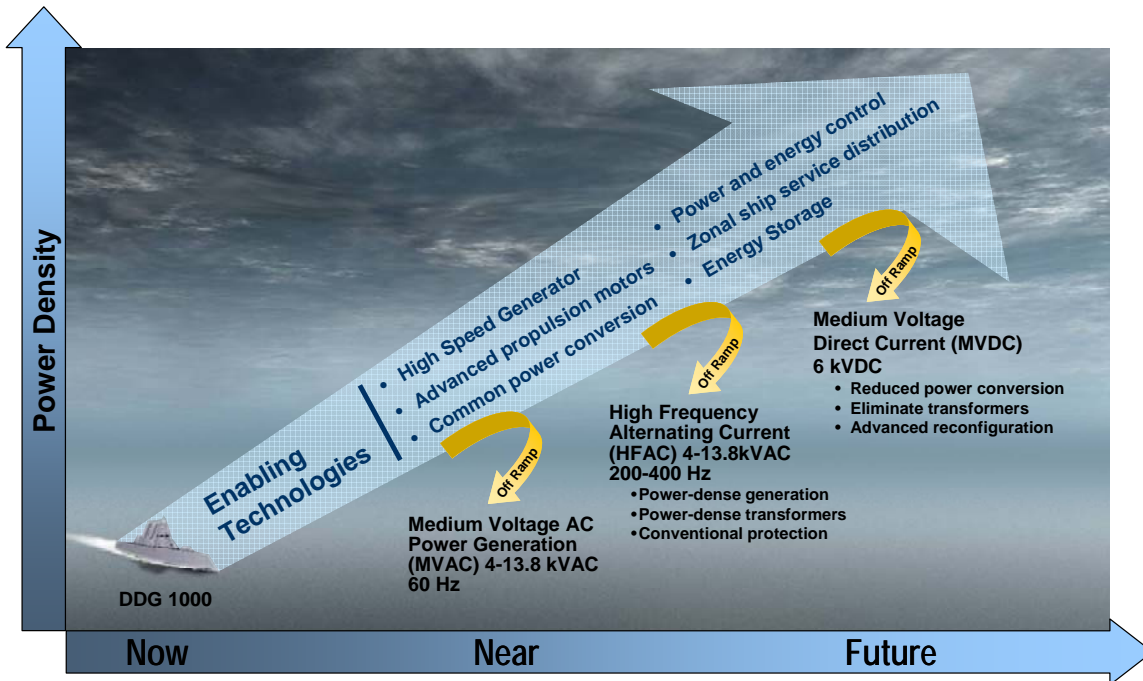

Figure 1: NGIPS Technology Development Roadmap

TABLE OF CONTENTS

Executive Summary	I
Table of Contents	iii
List of Figures.....	vi
List of Tables	vi
List of Acronyms.....	vii
1. Introduction / Background	1
2. NGIPS Open Architecture Business Model.....	7
2.1 Required Capabilities.....	9
2.2 Derived Requirements / System Design and Engineering	9
2.3 Architect.....	9
2.4 Module Development (with Government program management).....	10
2.5 Non-Developmental Item (NDI)-Modules	10
2.6 System Integration	10
2.7 Life Cycle Support.....	10
2.8 Government Oversight.....	10
3 NGIPS Technical Architecture Overview	13
3.1 Medium Voltage AC Power (MVAC).....	13
3.2 High Frequency AC Power (HFAC).....	16
3.3 Medium Voltage DC Power (MVDC).....	20
3.4 Zonal Electrical Distribution Systems	22
3.5 Power Generation Modules (PGM)	27
3.5.1 Gas Turbines	27
3.5.2 Diesel Engines	28
3.5.3 Fuel Cells	28
3.5.4 High Speed Generators	29
3.5.5 Rectifiers and Inverters.....	30
3.6 Propulsion Motor Modules (PMM)	30
3.6.1 Normal Power Density Propulsion Motors.....	30
3.6.2 High Power Dense Propulsion Motors	30
3.6.3 Motor Drives.....	31
3.6.4 Advanced Propulsion.....	31
3.6.5 Hybrid Drives.....	33
3.7 Power Load Module (PLM).....	34
3.7.1 Categorizing and Amalgamating Loads.....	34
3.7.2 Flexible Load Power Interface.....	34
3.7.3 Load Control Interface.....	34
3.7.4 Pulse Power Support	35
3.8 Power Distribution Module (PDM)	36
3.8.1 Switchgear.....	36
3.8.2 Cable	36
3.8.3 Load Control Interface.....	36
3.8.4 Controllable Bus Transfer.....	37
3.9 Power Conversion Module (PCM)	37
3.9.1 PCM-1A.....	37

3.9.2	PCM-2A.....	38
3.9.3	60 Hz. Transformers	39
3.9.4	HFAC Transformers	39
3.9.5	Shore Power Interface.....	40
3.10	Energy Storage Modules (ESM).....	40
3.11	Power Control Module (PCON)	41
3.12	Systems Architecting and Engineering.....	42
4	Technology INSERTION AND ENGINEERING Roadmap	45
4.1	Medium Voltage AC Power (MVAC).....	45
4.2	High Frequency AC Power (HFAC).....	45
4.3	Medium Voltage DC Power (MVDC).....	46
4.4	Zonal Electrical Distribution Systems (ZEDS).....	47
4.5	Power Generation Modules (PGM)	48
4.6	Propulsion Motor Module (PMM).....	48
4.7	Power Load Module (PLM).....	49
4.8	Power Distribution Module (PDM)	50
4.9	Power Conversion Module (PCM)	50
4.10	Energy Storage Module (ESM)	51
4.11	Power Control Module (PCON)	52
4.12	Systems Architecting and Engineering.....	52
5	Conclusions & Recommendations	55
6	Bibliography	57
	Appendices.....	61
	Appendix A Quality of Service and Zonal Survivability	63
A.1	Surface Ship Survivability: Zonal Survivability.....	63
A.2	Submarine Survivability	65
A.3	Quality of Service	65
	Appendix B NGIPS Functional Architecture.....	67
B.1	Power Generation:	67
B.2	Power Distribution:.....	67
B.3	Power Conversion:.....	67
B.4	Power Load:	68
B.5	Energy Storage:.....	68
B.6	System Control:	68
	Appendix C Power Density and Ship Size.....	69
	Appendix D Industry Trends	73
	Appendix E NGIPS Technology Development Roadmap Details.....	77
E.1	Medium Voltage AC Power (MVAC).....	77
E.2	High Frequency AC Power (HFAC).....	78
E.3	Medium Voltage DC Power (MVDC).....	80
E.4	Zonal Electrical Distribution Systems (ZEDS).....	84
E.5	Power Generation Modules (PGM)	86
E.6	Propulsion Motor Modules (PMM)	89
E.7	Power Load Module (PLM).....	93
E.8	Power Distribution Modules (PDM).....	94
E.9	Power Conversion Modules (PCM).....	96

E.10	Energy Storage Module (ESM)	101
E.11	Power Control Module (PCON)	103
E.12	Systems Architecting and Engineering	106

LIST OF FIGURES

Figure 1: NGIPS Technology Development Roadmap	II
Figure 3 Future Warship Power Demand	2
Figure 4 NGIPS Ship Insertion Timeline – 30 Year Shipbuilding Plan	4
Figure 5: Open Architecture Business Model.....	8
Figure 6 DOD Architectural Framework.....	8
Figure 7: Notional MVAC Distribution System interfacing with IFTP	15
Figure 8: Notional MVAC Distribution System Interfacing with ACZEDS.....	15
Figure 9: PDM Bus Voltage for MVAC Distribution	16
Figure 10: HFAC Distribution System	19
Figure 11: Alternate HFAC Distribution System with IFTP	19
Figure 12: ACZEDS with interface to MVAC	23
Figure 13: ACZEDS with interface to HFAC.....	23
Figure 14: ACZEDS with interface to MVDC	24
Figure 15: Current Generation IFTP.....	25
Figure 16: Potential Future IFTP in-zone architecture	27
Figure 17 Contra Rotating Propeller with a Podded Drive.....	32
Figure 18 FFG-7 Auxiliary Propulsion Units	33
Figure 19: Notional Railgun Power Interface.....	35
Figure 20: Notional PCM-1A Architecture	38
Figure 21: Machinery Economy of Scale	69
Figure 22: Group 2 Percentage of Full Load Displacement vs ship Length.....	70
Figure 23: Payload Percentage of Full Load Displacement vs Ship length.....	71
Figure 24: Full Load Displacement vs Length for scaled ASSET ship concepts.....	72

LIST OF TABLES

Table 1: Ship applications for NGIPS requirement categories	3
Table 2: Power Architectures for NGIPS Requirement Categories	5
Table 3: MVAC Largest Generator Or Load Vs. Voltage Based On Circuit Breaker Limits	14
Table 4: MVAC Maximum Bus Power Based On Fault Current Interruption Capability	14
Table 5 Generator frequency for given prime mover RPM and number of generator pole pairs	20
Table 6: Draft MIL-PRF-XX4315 IPNC Input and Output Modules for PCM-2A	39

LIST OF ACRONYMS

ABT	Automatic Bus Transfer
ACZEDS	Alternating Current Zonal Electrical Distribution System
CBT	Controllable Bus Transfer
COTS	Commercial Off The Shelf
DODAF	Department of Defense Operational Framework
EMALS	Electromagnetic Aircraft Launch System
EMC	Electro-Magnetic Compatibility
EMI	Electro-Magnetic Interference
ESM	Energy Storage Module
HFAC	High Frequency Alternating Current
HM&E	Hull, Mechanical and Electrical
IEEE	Institute of Electrical and Electronics Engineers
IFTP	Integrated Fight Through Power
IPA	Integrated Power Architecture
IPNC	Integrated Power Node Center
IPS	Integrated Power System
JCIDS	Joint Capabilities Integration and Development System
MVAC	Medium Voltage Alternating Current
MVDC	Medium Voltage Direct Current
NGIPS	Next Generation Integrated Power System
NSWCCD	Naval Surface Warfare Center Carderock Division
NVR	Naval Vessel Rules
OA	Open Architecture
OATF	Open Architecture Task Force
OPNAV	Office of the Chief of Naval Operations
PCM	Power Conversion Module
PCON	Power Control Module
PDM	Power Distribution Module
PFN	Pulse Forming Network
PGM	Power Generation Module
PLM	Power Load Module
PMM	Propulsion Motor Module
QOS	Quality of Service
SSCM	Ship Service Converter Module
SSIM	Ship Service Inverter Module
TRL	Technology Readiness Level
ZEDS	Zonal Electrical Distribution System

(This Page Left Intentionally Blank)

1. INTRODUCTION / BACKGROUND

The Navy has been rapidly migrating toward ship designs with electric propulsion and weapon and support systems demanding substantially more electrical power. To address these power demands, ship designs are using integrated power systems that provide electric power either to propulsion or other electrical loads from a common source.

The Navy initiated the Next Generation Integrated Power Systems (NGIPS) effort, with centralized leadership by the Electric Ships Office (ESO), to provide direction for future IPS developments. This NGIPS Technology Development Roadmap defines the path for future NGIPS development, provides guidance for the ESO, ONR and other developing organizations, and will form the basis for coordinated planning and investment by the Navy.

The primary aim of the design of a ship board electric power system is survivability and continuity (reliability) of the electrical power supply. Survivability relates to the ability of the power system, even when damaged, to support the ship's ability to continue fulfilling its missions to the degree planned for a particular threat. Quality of Service (QOS) serves as a metric of the continuity (reliability) of the electrical power supply by measuring the adequacy of distributed systems support for the normal, undamaged operation of its loads. A more detailed discussion of survivability and QOS is covered in Appendix A.

Between 1992 and 2007, the U.S. Navy invested significantly in the development of the Integrated Power System (IPS). IPS integrates the electrical power generation and ship propulsion systems. Although IPS technology development successfully focused on DDG 1000, its primary goal has, and continues to be, meeting surface ship requirements at the lowest possible cost. In addition to the IPS technical architecture implemented on DDG 1000, the Navy has also implemented more commercial IPS solutions to the T-AKE 1 class and a hybrid solution on LHD 8 and LHA 6. [Doerry and Davis 1994] [Doerry et. al. 1996] [Dalton et. al. 2002]

The need for integrated power systems will increase in the coming decades. Figure 2 shows the projected propulsion and ship service power demands for future combatants armed with advanced sensors and future weapons such as railguns and lasers. Integrated propulsion systems are also projected to benefit the signature performance of future submarine classes. For expeditionary warfare ships, combat logistics ships, Maritime Prepositioning Force – Future (MPF(Future)), and support vessels, reduced fuel costs and overall reductions in life cycle cost will continue to drive to integrated power solutions.

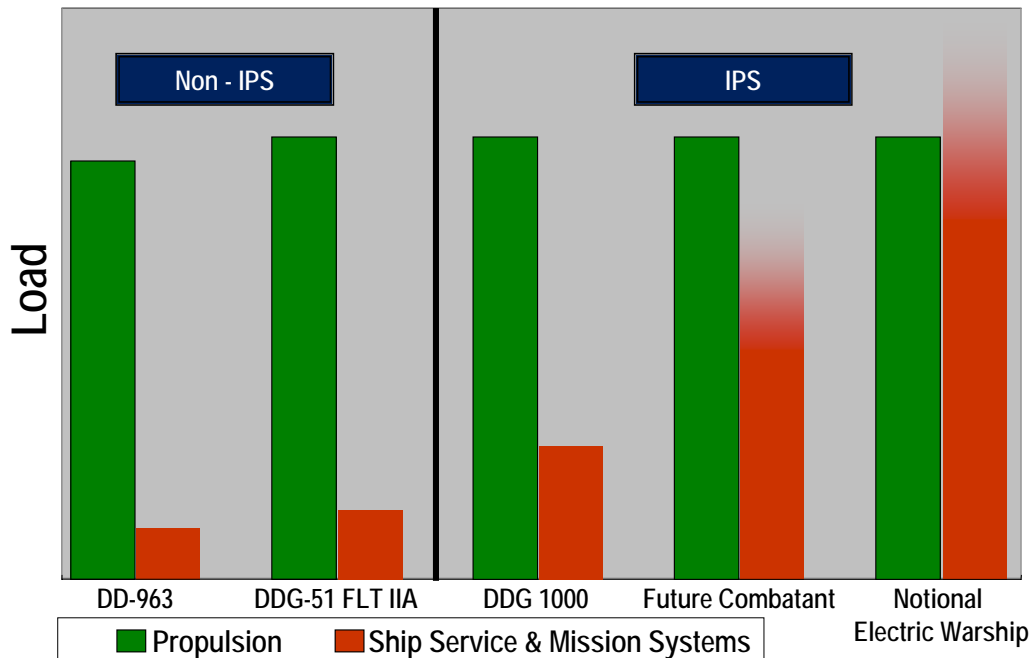

Figure 2 Future Warship Power Demand

As the Navy transitions the DDG 1000 to detail design and construction, re-examining the IPS architecture in preparation for the next classes of future surface combatants, amphibious warfare ships, auxiliaries and submarines is warranted. The Next Generation Integrated Power System (NGIPS) incorporates the lessons learned from the IPS efforts to date to develop an open architecture technical and business approach to procuring power systems. Recognizing that the appropriate affordable power system for different types of ships may require different technologies, NGIPS categorizes applications by the required power density and Quality of Service requirements. Ships with a very high speed requirement with a low ship service electrical load such as LCS and JHSV are not good candidates for NGIPS power systems.

Table 1 categorizes the different ship types that comprise the U.S. Navy fall into the different NGIPS requirement categories. Figure 3 shows the NGIPS insertion timelines for the ship applications in Table 1. The differentiation between small and large surface combatants is not precise. As shown in Appendix C, smaller ships profit more from power density than larger ships. In general, surface combatants less than 10,000 lton full load displacement can be considered “small” and those larger than 25,000 lton full load displacement can be considered “large.” For the purpose of selecting the appropriate NGIPS architecture, surface combatants falling between 10,000 and 25,000 lton may fall in either the small or large surface combatant categories. Trade-studies during Preliminary Design can provide the optimal solution.

	Enhanced Quality of Service Requirements	Standard Quality of Service Requirements
High Power Density Requirements	Small Surface Combatants, Submarines	High Speed Support Vessels
Standard Power Density Requirements	Large Surface Combatants	Expeditionary Warfare Ships, Combat Logistics Ships, MPF (Future), Moderate Speed Support Vessels,

Table 1: Ship applications for NGIPS requirement categories

Table 2 presents four different NGIPS power architectures and maps them to the NGIPS requirement categories. Details of these architectures are provided in section 3. The MVAC Power architecture employs mature technologies and does not require Science and Technology (S&T) investment for deploying these architectures. Some R&D work is required to update design data sheets, Naval Vessel Rules, and other design standards. DDG-1000 is proving the technical viability of the Integrated Fight Through Power (IFTP) ship service zonal electrical distribution system. Additional R&D work is needed to refine system design methodologies, modify component designs to improve system performance and reduce costs, and update design data sheets, Naval Vessel Rules and other design standards. For ships requiring high power density, the long term solution will be Medium Voltage DC systems. Before MVDC can be applied to warships however, a number of S&T issues must be resolved. For the near-term, High-Frequency AC power can provide an interim technological step to improve power density on the path to MVDC. Although engineering challenges remain in integrating a HFAC system, the technology is mature enough to not need S&T or early R&D investment. The roadmap for maturing these different architectures is covered in greater detail in section 4.

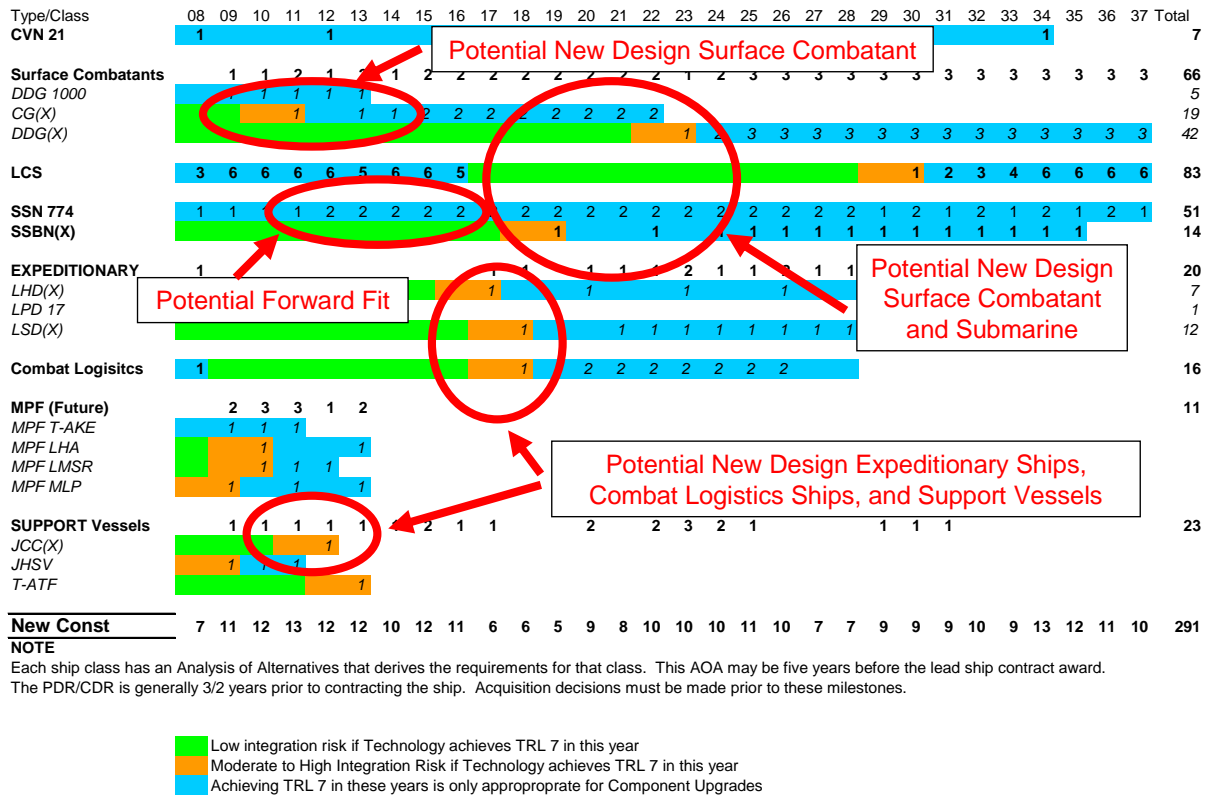

Figure 3 NGIPS Ship Insertion Timeline – 30 Year Shipbuilding Plan

The open architecture business approach for NGIPS is also crucial for its success. Historically, power systems have often been procured as a “turn-key” solution from a single vendor that designs, procures, delivers, and tests the complete power and propulsion system. The drawbacks to this practice include:

- a. The single vendor will tend to constrain component choices to its own product line and not always take advantage of potential competitor’s technologies.
- b. There are many barriers to incorporating lessons learned from fielded systems.
- c. The single vendor typically does not have an incentive to maximize commonality across the fleet.
- d. The ability to transition Government S&T and R&D investments is limited to what the single vendor will accept.

	Enhanced Quality of Service Requirements	Standard Quality of Service Requirements
High Power Density Requirements	Power Generation: Goal: Medium Voltage DC (MVDC) Interim: High Frequency AC (HFAC) Enhanced QOS features incorporated into Zonal Electrical Distribution	Power Generation: Goal: Medium Voltage DC (MVDC) Interim: High Frequency AC (HFAC) Standard QOS features incorporated into Zonal Electrical Distribution
Standard Power Density Requirements	Power Generation: Medium Voltage AC (MVAC) Enhanced QOS features incorporated into Zonal Electrical Distribution	Power Generation: Medium Voltage AC (MVAC) Standard QOS features incorporated into Zonal Electrical Distribution

Table 2: Power Architectures for NGIPS Requirement Categories

In contrast, the NGIPS open architecture approach splits the responsibilities for an NGIPS system to enable specialization of function. The NGIPS roles currently defined are:

- a. Ship Requirements Developer
- b. Ship Systems Engineer
- c. Architect
- d. Module Developer
- e. Systems Integrator
- f. Lifecycle Maintainer
- g. Government Oversight

This approach enables the application of a common design, development, and support process for all NGIPS ships. Furthermore, it enables smooth transition of technology from S&T through R&D and into fielded systems. In this way, NGIPS offers the Navy a method for the continuous improvement in both cost and capability of its power system architectures. Details of the NGIPS Open Architecture approach are contained in section 2.

(This Page Left Intentionally Blank)

2. NGIPS OPEN ARCHITECTURE BUSINESS MODEL

A recent Open Architecture Task Force (OATF) defined Naval Open Architecture (OA) as ...

"Naval OA is a combination of collaborative-competition business and technical practices; including Peer Reviews for cost-effective innovation, with rapid Technology Insertion processes fostering third-party developed modules (hardware and/or software), for continuous, incremental increases in warfighting capability, while reducing cost."

It should be noted that “developers” can include S&T centers of excellence, Labs, Small Business Innovative Research institutions, non-traditional defense vendors, and other sources. By opening the business model and using a designated System Integrator, rather than a single Prime developer, innovation and competition are leveraged across the entire commercial base.

The OATF concentrated on applying the Open Architecture Technical and Business Model to combat systems. This section adapts these concepts to NGIPS.. Some of the differences between Combat Systems and HM&E systems such as NGIPS include:

- Historically, hardware and software technical innovation has occurred at a slower pace in HM&E systems. Increased attention to power systems may accelerate innovation.
- The continuous, incremental increases in capability are generally applied to classes of ships, or flights within a class, not necessarily to the same ship over its lifetime. In some cases, such as Machinery Control Systems and Power Converters, hardware and/or software refresh may occur one or more times over the life of the ship. Of more importance, is the ability to affordably add to the capacity of a distributed system over the ship’s life, rather than installing considerable Service Life Allowance during ship construction.

The OA Business Model is based on successful programs that rapidly delivered significant operational capability upgrades at lower costs and successful commercial market examples. Both sets of examples had the following key principles:

- The use of Performance Specifications that define “what” is needed not “how” it is designed (Note: Performance Specifications are also characterized by their extensive use of well-defined and detailed interface specifications in addition to well defined validation methods) ;
- Subdivision of labor or specialization at the module or component level;
- Defining and segregating roles and responsibilities for component delivery, system integration and life cycle support; and
- The criticality of a feedback process to create a “spiral” process to provide feedback from the evaluation of fielded systems to update architecture documentation and module designs.

The OA Business model depicted in Figure 4 describes the basic business model for military acquisition programs that fully embrace advantages and opportunities available with COTS technologies. This business model is aligned with the Operational, Technical Standards, and Systems views of the DOD Architectural Framework (DODAF) shown in Figure 5.

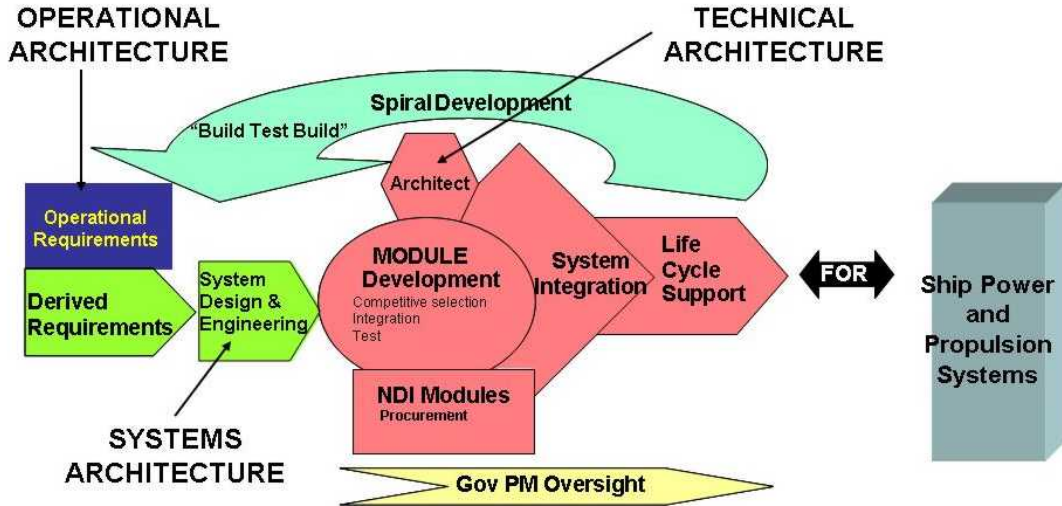

Figure 4: Open Architecture Business Model

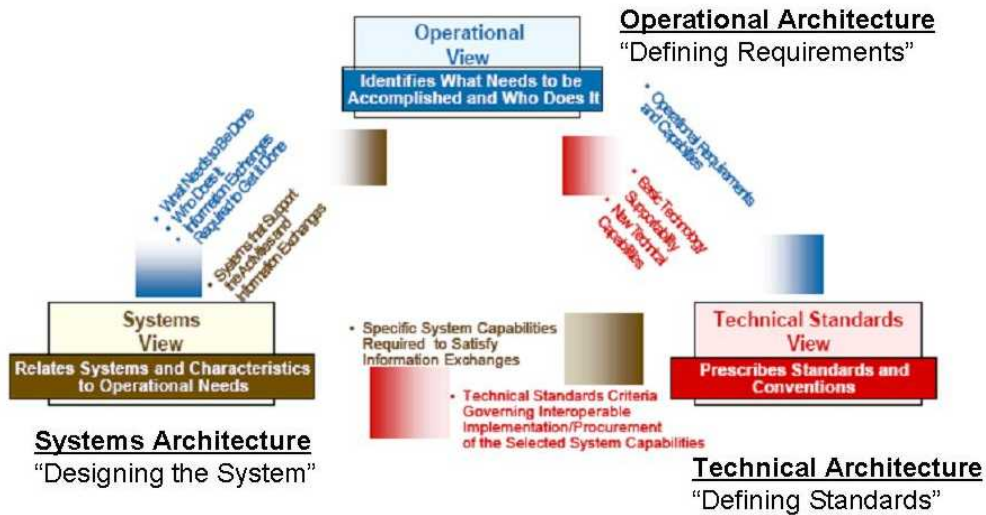

Figure 5 DOD Architectural Framework

2.1 Required Capabilities

Required capabilities developed by OPNAV as part of the JCIDS process form the basis of the Department of Defense Architectural Framework (DODAF) “Operational Architecture”.

2.2 Derived Requirements / System Design and Engineering

Derived Requirements for the Power and Propulsion system for a given ship acquisition program are developed by the ship design team. This ship design team could be either Government or Industry led. Normally there will be a Power and Propulsion Systems Engineering Manager assigned to the design team that will lead the engineering efforts of the power and propulsion system.

The Derived Requirements are used to determine the DODAF “systems architecture” and module selection for the power and propulsion system.

2.3 Architect

The architect function is led by the Technical Warrant Holder for NGIPS and is generally concerned with the maintenance of the DODAF “technical architecture” for NGIPS. The government Technical Warrant Holder is supported by a government / industry peer review team. The architect function is concerned with cross-platform issues and only becomes involved with specific ship issues when deviations or waivers to the standard processes are needed.

Responsibilities include:

- Custodianship of the NGIPS architecture to include

- a. Development and maintenance of standards and specifications such as Naval Vessel Rules (NVR), military specifications and standards as well as participation in industry standards bodies such as IEEE
- b. Development and maintenance of interface specifications and validation / testing standards for NGIPS module types.
- c. Development and maintenance of standard performance specifications for NGIPS module types.
- d. Development and maintenance of design data sheets and associated design and analysis tools.
- e. Development and maintenance of reference power system designs and reference machinery system concept of operations.

- Development and maintenance of computer-based modeling and simulation capability for the NGIPS adequate to support establishing standards and interfaces and integrating new technology throughout the life of the ship. Distribution of this information appropriately to industry and government.

- Development and maintenance of Module Characterization Sheets for capturing data on qualified and developmental modules for use with design and analysis tools.

- Identification and tracking of NGIPS risks

- In collaboration with a Peer Review process, ship concept analyses and force architecture studies, development and maintenance of a technology roadmap / priority list for desired technology improvements

2.4 Module Development (with Government program management)

Government Program Management, based on the technology roadmap, prepares specifications / Statements of Work for development contracts in conformance with the NGIPS Technical Architecture.

The Module Developer is responsible for maturing the technology and “qualifying” the module through the module validation and testing standards.

2.5 Non-Developmental Item (NDI)-Modules

Vendors of qualified modules work with the Architect to ensure Module Characterization Sheets are kept up-to-date and to re-qualify modules following design changes.

2.6 System Integration

The Systems Integrator uses the derived requirements from the systems engineering process, the technical architecture, and results from analysis, modeling and simulation to produce module procurement specifications. To preclude conflicts of interest, the Systems Integrator must be independent of the source selection of vendors for the module procurements.

Once the procurement is made (by either the government or the ship integrator / ship builder) the Systems Integrator assists the government in ensuring the vendor is meeting the procurement specifications, continues to validate that the Power and Propulsion system will work (and if not, what Engineering Changes are needed to make it work), and participates in component and system testing.

2.7 Life Cycle Support

Following fleet introduction of an IPS warship, an organization, either Government or industry led, manages the IPS configuration of in-service ships. This life cycle support activity would perform reliability analysis, equipment condition trending analysis, and maintenance analysis as well as addressing modernization, safety, environmental, reliability, diminishing sources, and obsolescence issues. The life cycle support organization, in concert with appropriate technical warrant holders, would develop and promulgate safe operating procedures and safe operating envelopes. This activity would also develop maintenance requirements, procedures, and plans. When needed, the life-cycle support organization would provide assistance in adjudicating Departure from Specifications and other critical fleet issues. The life cycle support organization would also assist in maintaining educational skill requirements of the work-force, and when needed, assist in evaluating the actual skill level of the work-force. The life cycle support organization provides feedback to the architect on suggested improvements to the Technical Architecture documents.

2.8 Government Oversight

An open architecture approach is very different from the “turn-key” systems that have often been specified in previous ship acquisition programs. In an open architecture approach, the Government

plays an important role in the design, procurement, and integration of systems and system modules. A skilled, knowledgeable, and empowered Government workforce is vital to ensuring that the standards, specifications and other documentation comprising the technical architecture are kept up to date and reflect advances in technology to achieve desired levels of performance at lowest cost. Without continuous vigilance, open architecture technical practices and business practices can quickly devolve into application specific interfaces and solutions that negate the benefits of open architecture. On the other hand, an open architecture must not become bureaucratic or so dogmatic that technical architecture can not support the development of affordable and effective systems architectures. Strong government technical leadership, supported by a capable team of Government and contractor engineers and acquisition specialists is needed to ensure the successful implementation of an open architecture approach.

(This Page Left Intentionally Blank)

3 NGIPS TECHNICAL ARCHITECTURE OVERVIEW

In Section 1, four different power architectures were presented to meet the power requirements of the many classes of ships comprising the United States Navy. For power generation, high power distribution, propulsion, and large loads, NGIPS includes the following three power architectures:

- a. Medium Voltage AC Power (Emphasize Affordability)
- b. High Frequency AC Power (Near Term – Emphasize Power Density)
- c. Medium Voltage DC Power (Goal - Emphasize Power Density)

For Ship Service electrical loads, NGIPS includes zonal electrical distribution:

- d. Zonal Electrical Distribution

While the details of the power and control interfaces will differ in each of the power architectures listed above, they all adhere to the same NGIPS functional architecture described in Appendix B.

Sections 3.1 through 3.4 describe each of the different Technical Architectures listed above in greater detail. Sections 3.5 to 3.11 address specific technical issues and required activities that apply to several or all of the technical architectures’

- a. Power Generation Modules
- b. Propulsion Motor Module
- c. Power Load Module
- d. Power Distribution Modules
- e. Power Conversion Modules
- f. Energy Storage Module
- g. Power Control Module

The final section, Section 3.12, details overarching Systems Engineering efforts needed to implement the Open Architecture Business Model as well as support ship acquisition programs.

3.1 Medium Voltage AC Power (MVAC)

Ship designs where high power density is not required should use a Medium Voltage AC Power (MVAC) Technical Architecture. A MVAC system is compatible with both an IFTP and an ACZEDS ship service power distribution system. Figure 6 shows a notional MVAC system interfacing with IFTP while Figure 7 shows a notional MVAC system interfacing with ACZEDS.

In an MVAC system, power is generated as 3 phase 60 Hz. power at one of three standard voltages: 4.16 kV, 6.9 kV, or 13.8 kV using a high-impedance ground. The selection of voltage is based on the availability of circuit breakers of sufficient rating both for normal operation and fault current interruptions. Table 3 shows typical limits for the power rating of the largest generator or load in the power system. Table 4 shows the typical limits for the total amount of generation that can be paralleled at once (a .95 Power Factor (PF) is used if most of the load is propulsion or DC Zonal

Electrical Distribution, otherwise a .80 PF is used). In many ship designs, split plant operation is used at higher power levels, thereby doubling the total ship power generation capacity limits shown in Table 4. In practice, one can purchase non-standard circuit breakers with somewhat larger current capacity for a significant increase in cost and complexity (For example, 4000 amp breakers are available, but require forced air cooling). Likewise, the total amount of generation can be adjusted somewhat by either generator design to limit fault current (the table assumes maximum fault current rating is 8 times rated current based on derating the maximum fault current of the breakers by 20% and a 16% generator subtransient reactance) or paying substantially more for circuit breakers with higher fault current interrupt capability. Additionally, at a cost of extra control system complexity, other work-arounds are possible to increase the allowable bus MVA shown in Table 4. Assuming Power Generation Modules are selected to provide equal capacity on two split buses, Figure 8 shows the range of Total Power System Power that each voltage level can support (450 VAC is shown only for comparison). Note that the overlap in power ranges allows the system designer some flexibility in selecting a power generation voltage for a given application. Staying within the specified power ranges for a given bus voltage enables the use of COTS derivative generators, switchgear, cabling, and other distribution system equipment. With current technology, systems employing 4.16 kV can employ motor drives without a large, heavy and expensive propulsion transformer. Anticipated improvements in commercial motor drive technology will enable the use of transformerless propulsion motor drives at 6.9 kV in the near future.

Voltage Level	Breaker Rating (amps)	MVA	MW @.95 PF	MW @.80 PF
450	4000	3.1	3.0	2.5
4160	3500	25.2	24.0	20.2
6900	3500	41.8	39.7	33.5
13800	3500	83.7	79.5	66.9

Table 3: MVAC Largest Generator Or Load Vs. Voltage Based On Circuit Breaker Limits

Voltage Level	Typical maximum Fault Current (amps)	Approx Bus MVA allowable	Approx Bus MW allowable @.95 PF	Approx Bus MW allowable @.80 PF
450	85000	8	8	7
4160	47000	42	40	34
6900	39000	58	55	47
13800	68000	203	193	163

Table 4: MVAC Maximum Bus Power Based On Fault Current Interruption Capability

In developing NGIPS configurations using the MVAC architecture, engineering effort is required to qualify components for military applications, integrate the power system with overall shipboard machinery control system, and integrate the overall system. In general, Science and Technology and early stage Research and Development funds are not needed to support the MVAC technical Architecture. Updating of design documentation, standards, and the Naval Vessel Rules are still required and discussed in the roadmap in section 4.

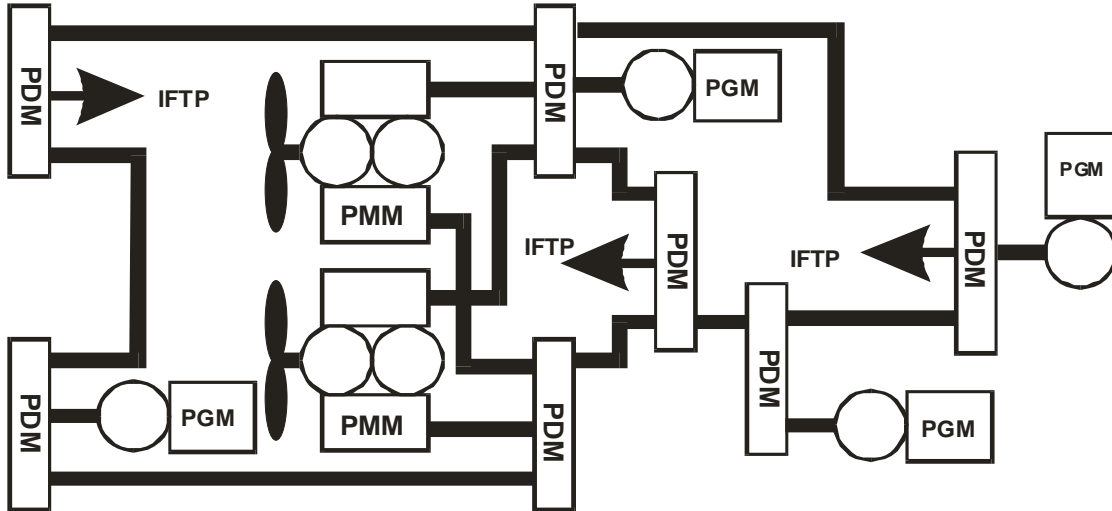

Figure 6: Notional MVAC Distribution System interfacing with IFTP

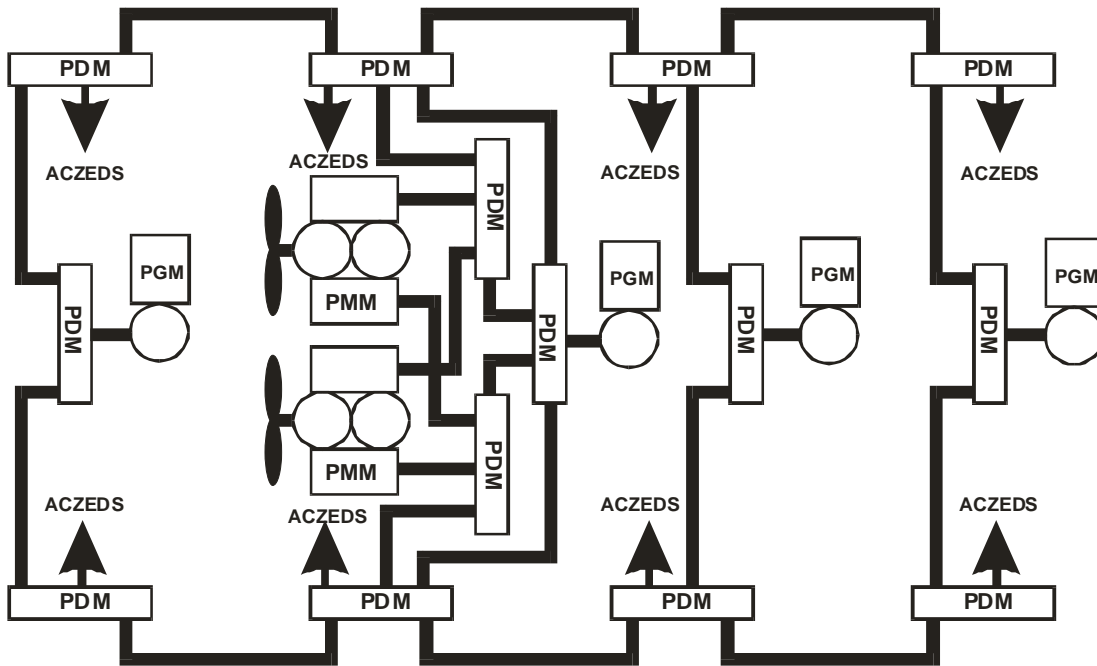

Figure 7: Notional MVAC Distribution System Interfacing with ACZEDS

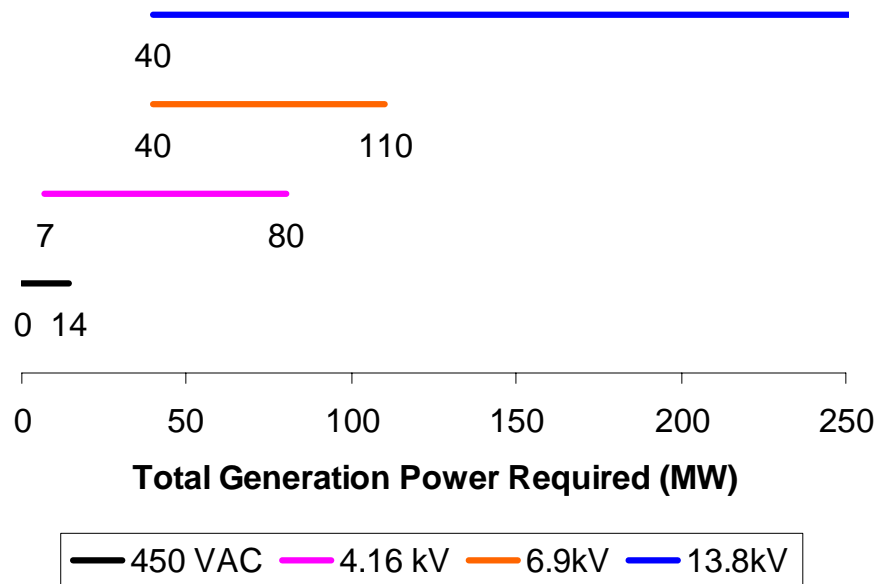

Figure 8: PDM Bus Voltage for MVAC Distribution

3.2 High Frequency AC Power (HFAC)

Figure 9 shows a notional High Frequency AC (HFAC) Power Generation Architecture compatible with both ACZEDS and IFTP ship service distribution systems. Figure 9 shows an alternate HFAC Power Generation Architecture that may proved less expensive when integrated with IFTP. Power is generated at a fixed frequency greater than 60 Hz. and less than 400 Hz. Most likely, the distribution voltage will be either 4.16 or 13.8 kV using a high-impedance ground. The advantages of a High Frequency AC (HFAC) power system include:

- a. Magnetics smaller & lighter than 60 HZ. The cross sectional area of a magnetic core of a transformer is approximately inversely proportional to the frequency of operation. Thus the weight of the transformer core (not including the windings) of a 240 Hz. transformer would be expected to be about ¼ the weight of a 60 Hz. transformer that uses the same core material.
- b. Harmonic filters minimized or eliminated. Because the propulsion motors would be employing 3 phase to multi-phase transformers, the current harmonics injected on the power bus would be substantially reduced, perhaps even to the level that would not require a harmonic filter. If a filter were necessary, the higher frequency operation would enable a much smaller filter than that required for 60 Hz. operation.
- c. Galvanic isolation between subsystems. A HFAC system would employ power dense transformers to isolate all loads from the HFAC high power bus. The transformers would minimize common mode currents from the power converters, limit the impact of ground faults, and limit transient over voltages. Additionally, transformers limits available short circuit current to power converters

- d. Improved acoustic performance over 60 Hz. Operation. By operating at a higher frequency than 60 Hz. the acoustic absorption of noise from equipment (such as transformers) vibrating at the power system fundamental frequency is greater in seawater. The average acoustical absorption $\langle a \rangle$ in seawater is given approximately by

$$\langle a \rangle \cong 0.04 f^{1.35} \text{ dB/km} \quad (f \text{ in kHz})$$

At 240 Hz., the acoustical absorption is about 6.5 times that at 60 Hz which reduces the ship's detection range. Additionally, sound isolation of equipment is lighter and easier at higher frequencies.

- e. Minimal technology development required vs MVDC

The challenges with implementing a HFAC system include:

- a. High number of poles required for generators interfaced with “slower” prime movers. Table 5 shows the frequency obtainable for a given prime mover speed and number of pole pairs. For the range of prime movers of interest to shipboard applications, a frequency within the range of 240 to 360 Hz is likely optimal, but further study is needed. One implication for operating in this frequency range is that due to the large number of required generator pole pairs needed for 1800 rpm operation, medium speed diesel engines would require either the use of a speed increasing gear, or some type of advanced technology generator. Permanent Magnet generators can support high numbers of pole pairs, but do not have the requisite ability to regulate voltage needed to directly interact with a power system (Some type of developmental in-line voltage regulator would be needed). Gas turbines that operate at 3600 rpm would also likely need increasing gears or advanced technology generators to operate above 240 Hz. High speed (7200 - 14400 RPM) gas turbines and steam turbines could use conventional round rotor synchronous machine technology.
- b. Because generator frequency is a multiple of generator speed, prime movers are restricted to specific operating speeds. This may result in sub-optimal fuel efficiency or dynamic responsiveness.
- c. Because all of the loads on a HFAC bus will likely behave as constant power loads with negative incremental impedances, careful design is required to ensure system stability. While much progress has been made in developing generalized methods for assuring system stability within the science and technology realm, translating these methods into robust specifications, standards and integration techniques is still required.
- d. Higher frequency operation above 60 Hz. requires derating of cable and switchgear designed for 60 Hz. The derating factors for cable and switchgear and guidance for bus voltage require further study. Preliminary analysis indicates the derating factor for operating COTS circuit breakers at 240 Hz. will be on the order of 0.70. [Brick, et. al. 2007] Additionally, the impact of higher frequency operation on sensors, protective relays, switchboard controls, voltage regulators, and speed governors is not known.
- e. Ground fault current higher vs 60 Hz. Ground Fault current is a function of the line to ground parasitic capacitance. The impedance of a capacitor is inversely proportional to frequency, which means that as the system frequency increases with a constant capacitance,

the line to ground impedance decreases, resulting in higher ground fault currents. In fact, because cables must be derated, the number of cables and the line to ground capacitance will increase above that of a 60 Hz. system, further increasing the ground fault current. Use of additional components may be required to sectionalize the electrical distribution system, or otherwise reduce ground fault currents to allow continued system operations.

- f. Increased cable installation concerns (EMI, EMC, Inductive Heating). Additional losses and EMI generated in the cables may adversely affect other systems and equipment located near the cable ways. Inductive heating may impact cable raceways and penetrations. This may require larger equipment standoffs, or new designs for non-magnetic cable supports and penetrations. Component cable entry may need to be increased.
- g. A method for connecting to shore power must be established. Either the ship must convert the available 60 Hz. power into the HFAC required by the ship, or the shore power connection must provide the HFAC power.
- h. Limited higher frequency power test capability/infrastructure. Manufacturers are not likely to have test equipment or facilities to test their equipment at frequencies other than 60 Hz. Test equipment will either have to be made available to manufacturers, or the equipment will have to be tested at a dedicated test facility. Alternate test methods may also be developed to qualify equipment without using power sources at the design frequency.
- i. Paralleling of Generators at higher frequencies. Operation at higher frequencies reduces the window of time that a generator breaker can close to parallel a generator. The ability of existing breakers and paralleling controllers to operate within this narrower time window is not known.
- j. Lack of design standards, practices, guides, design tools, and supporting data. A design infrastructure is needed to ensure successful integration of HFAC systems in all stages of ship design.
- k. Higher frequency operation will result in a lower power factor as compared to MVAC systems. Low power factor translates into somewhat larger cabling and generators.

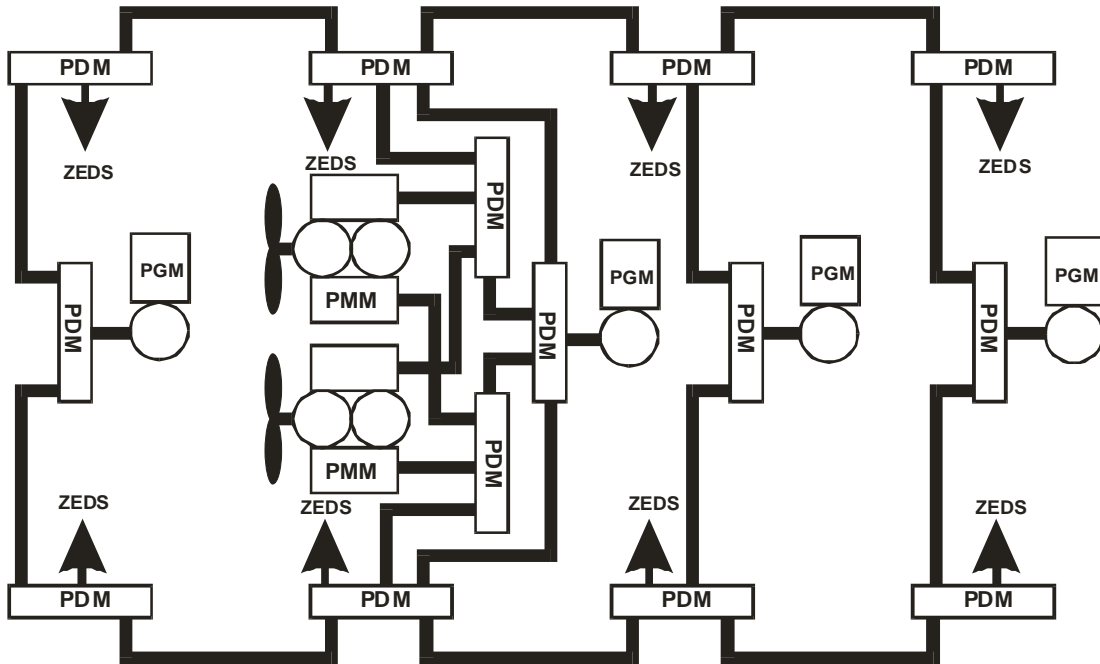

Figure 9: HFAC Distribution System

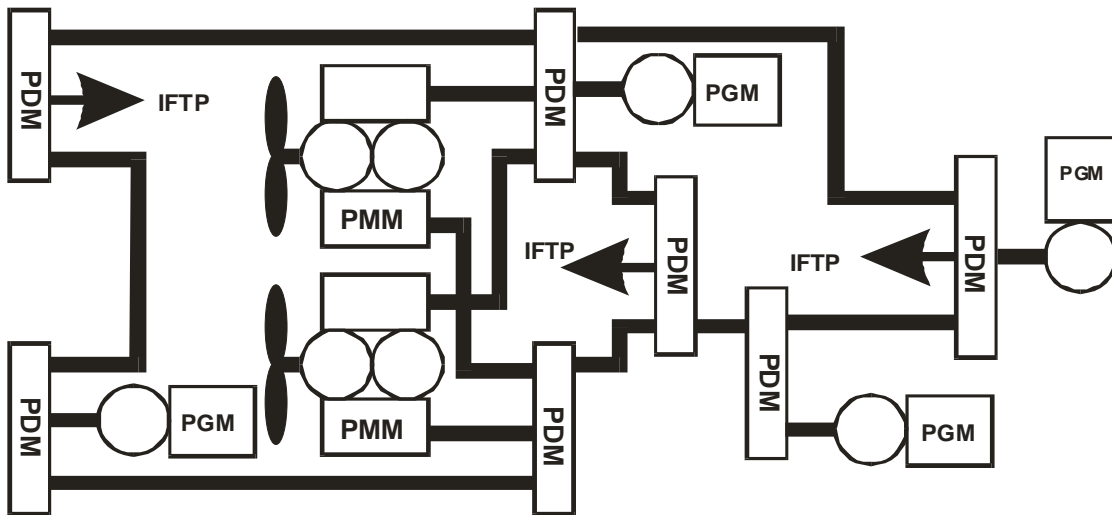

Figure 10: Alternate HFAC Distribution System with IFTP

	1800 RPM (Diesels)	3600 RPM (LM2500, MT30)	7200 RPM (LM500, Steam Turbines)	14,400 RPM (RR Allison 501, Steam Turbines)
1 Pole Pair (2 poles)		60 Hz	120 Hz	240 Hz
2 Pole Pairs (4 poles)	60 Hz	120 Hz	240 Hz	
3 Pole Pairs (6 poles)	90 Hz	180 Hz	360 Hz	
4 Pole Pairs (8 poles)	120 Hz	240 Hz		
5 Pole Pairs (10 poles)	150 Hz	300 Hz		
6 Pole Pairs (12 poles)	180 Hz	360 Hz		
8 Pole Pairs (16 poles)	240 Hz			
12 Pole Pairs (24 poles)	360 Hz			
	Increasing Gear or Advanced Technology	Conventional Technology		

Table 5 Generator frequency for given prime mover RPM and number of generator pole pairs

3.3 Medium Voltage DC Power (MVDC)

At a high level, the architecture for a Medium Voltage DC power system is identical to the HFAC systems depicted in Figure 9 and Figure 10. The primary difference is that instead of distributing High Frequency AC power through out the ship, the system distributes Medium Voltage DC power. This change though, impacts most of the power generation modules and requires S&T and R&D investment. The distributed power will likely employ balanced voltages around ground at one of 2 or 3 standard voltages in the range of $\pm 3,000$ VDC to $\pm 10,000$ VDC using a high-impedance ground. The primary reasons for employing an MVDC system include:

- a. Decouples prime mover speed from the frequency of the bus. Enables optimization of the generator for each type of prime mover without having to incorporate reduction gears or speed increasing gears. Generators are not restricted to a given number of poles. The speed can even vary across the power operating range of the prime mover to optimize on efficiency and /or responsiveness.
- b. Enables operation of power conversion equipment at frequencies an order of magnitude higher than with the HFAC system, resulting in even smaller transformers. If galvanic

isolation is proven not necessary, additional size reductions are possible. This is offset somewhat by the need for additional power conversion equipment to produce high frequency power.

- c. Reduces engineering concerns with respect to EMI and EMC present with HFAC systems.
- d. Potential reduction in cable weight (depending on voltage selection) due to lack of skin effect and reactive power.
- e. With power electronics closely connected with each electromagnetic device, increased ability to control fault currents to levels considerably lower than with ac systems.
- f. Improved acoustic performance over MVAC and HFAC systems. Since there is not a common frequency of vibrating equipment, the acoustic signature has a broader signature with fewer tonals that can be observed in the acoustic signature of the ship.
- g. The paralleling of generators only requires voltage matching and does not require time critical phase matching.
- h. Enables future high power demanding electric Mission Loads in a much more compact and power dense architecture.

The challenges with implementing an MVDC preclude a near term implementation of a shipboard MVDC system and include:

- a. Traditional fault detection and isolation techniques employed by conventional circuit breakers and based on fault current are not desirable for MVDC systems due to the difficulty in extinguishing DC arcs in the absence of a voltage or current zero crossing. Instead, MVDC is anticipated to use power electronics and advanced controls to quickly identify and isolate faults before large fault currents are generated. In the design of the power electronics, consideration must be made to ensure transient stability and limit potential over-voltages during transients. The details, methods, and standards for implementing a power electronics and advanced controls based fault detection and isolation require research and development in addition to implementation engineering. Additionally, new fault detection and isolation components may need to be developed.
- b. Because all of the loads on a MVDC bus will likely behave as constant power loads with negative incremental impedances, careful design is required to ensure system stability. While methods have been demonstrated on fielded systems for assuring system stability, translating these methods into robust specifications, standards and integration techniques is still required for application to MVDC systems.
- c. Standardized methods for controlling prime mover power and sharing loads between power generation modules must be established. In a.c. systems, real power is controlled through the speed governor, while reactive power is controlled through the voltage regulator. In d.c. systems without reactive power (not counting harmonic currents) power is controlled through the voltage regulator. Developing standardized methods for linking voltage regulation to the speed governor of the prime mover, and communicating load sharing data with other power generation modules require development.

- d. A grounding strategy for MVDC system must be established. The strategy must address the size and cost associated with providing galvanic isolation within power conversion modules with the risk for high, potentially dangerous, ground fault currents.
- e. Power Quality standards for MVDC require development. The standards have an impact on the size, weight, and cost for both rectifiers and the loads. Establishing standards that optimize the total system performance and cost across the range of ship applications is required.
- f. Lack of an established Industrial Base. The DC Switchgear as well as the power electronic fault detection and control systems needed to make shipboard MVDC systems viable have an insignificant commercial market. Consequently, the Navy will rely on a small industrial base of vendors with MVDC experience and will have to actively address risks associated with the loss of a key vendor through such methods as large number of contingency spares and establishing a large in-house engineering capability.
- g. Lack of design standards, practices, guides, design tools, and supporting data. A design infrastructure is needed to ensure successful integration of MVDC systems in all stages of ship design.
- h. A method for connecting to shore power must be established. Either the ship must convert the available 60 Hz. power into the MVDC required by the ship, or the shore power connection must provide the MVDC power.

3.4 Zonal Electrical Distribution Systems

Figure 11 shows a typical AC Zonal Electrical Distribution System (ACZEDS) implemented with a MVAC power generation system. Traditional transformers are used to convert the Medium Voltage power to 450 VAC power needed by loads. The power distribution module consists of traditional switchboards and load centers. Loads requiring compartment level survivability (See Appendix A) are provided redundant power through a Controllable Bus Transfer (CBT). A CBT differs from an Automatic Bus Transfer (ABT) in that it switches the source of power based on commands from PCON instead of shifting automatically. Un-interruptible loads are supplied either through an Energy Storage Module, by a solid-state fast ABT that can switch sources in less than 10 ms., or by a PCM-2A described below in the IFTP system. For AC Zonal Systems, the fast ABT solution is likely to be cheaper, although it does require the zonal transformers to potentially have a higher rating.

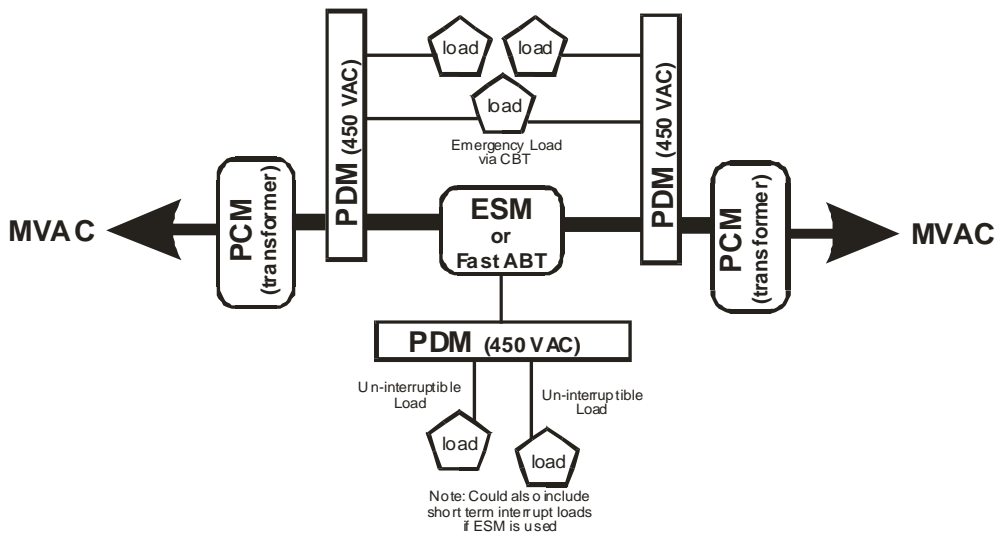

Figure 11: ACZEDS with interface to MVAC

Figure 12 shows that the major difference for a HFAC system is that the 60 Hz. transformer is replaced with a high frequency transformer, rectifier and inverter to produce the power for the ship service loads. In Figure 12, a converter with galvanic isolation is shown for the interface with the MVDC system. Although an additional inverter is included in the PCM, it can operate at a much higher frequency than 240 Hz (2 to 10 kHz is not unreasonable) to drive the size and weight of the transformer as small as possible. If studies show that galvanic isolation is not needed, then the PCM size can be significantly reduced. For both the HFAC and MVDC systems, the converter can be the PCM-1A described in the IFTP system described below.

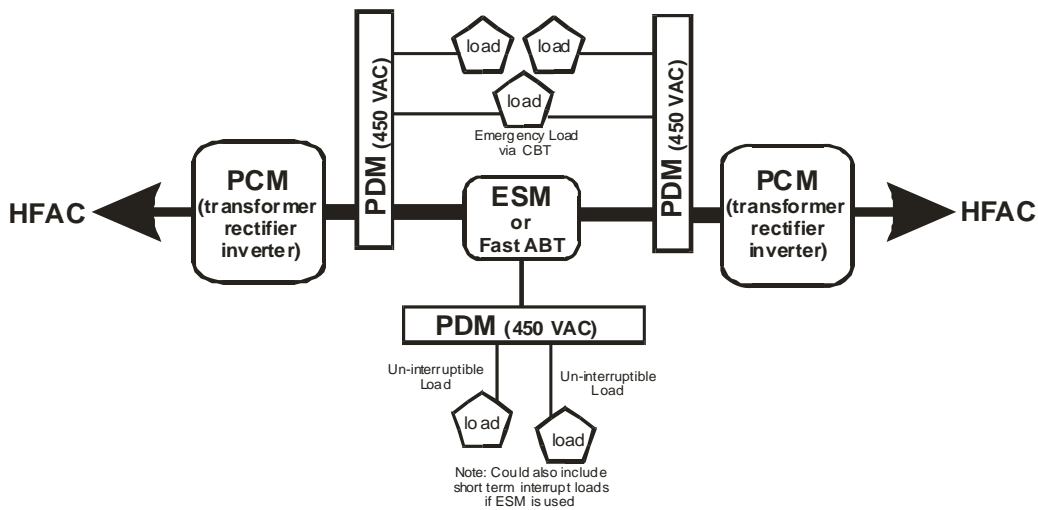

Figure 12: ACZEDS with interface to HFAC

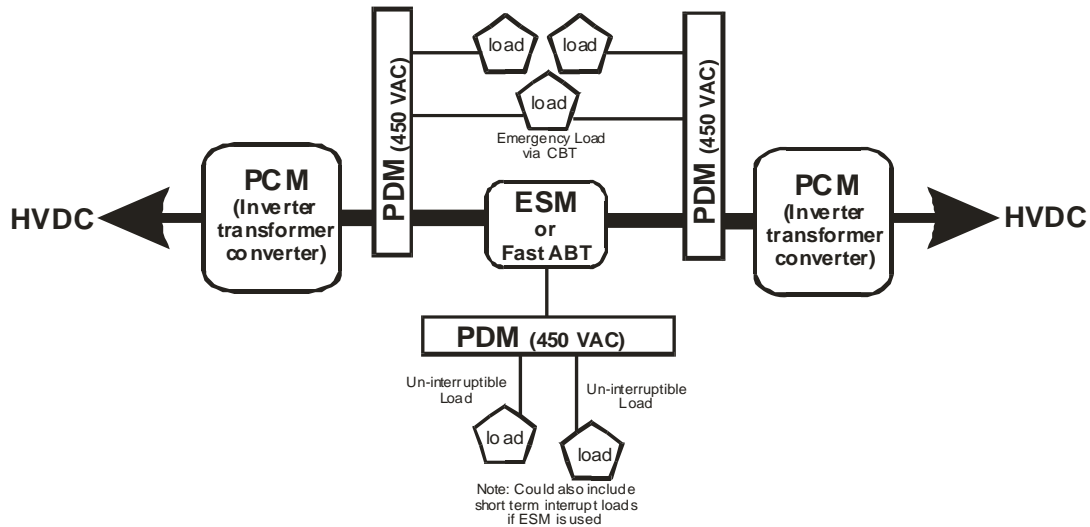

Figure 13: ACZEDS with interface to MVDC

The challenges with future implementations of an ACZEDS include:

- Design methods for estimating and characterizing loads into QOS categories: Un-interruptible, short-term interrupt and long term interrupt are needed as well as standard methods for implementing QOS and mission priority load shedding.
- The current methods for amalgamating loads for sizing distribution system equipment were developed to support radial distribution systems. The applicability of these methods to zonal systems has not been evaluated.
- The proper implementation of QOS and mission priority load shedding would be greatly facilitated by a control system interface standard for the PCON software to communicate with loads the need to turn off, reduce energy demand, or report future power needs.
- For loads that do not have control system interface, an inexpensive smart switch is needed to provide the ability of the PCON software to turn loads on or off.

Figure 14 shows a notional 3 zone Integrated Fight Through Power (IFTP) distribution system. An actual IFTP implementation would likely have 4 to 8 electrical zones instead of the three zones shown. An IFTP system features three types of power conversion modules:

- PCM-4: Transformer Rectifier to convert MVAC power to 1000 VDC power. The rating of the PCM-4 must be greater than $\frac{1}{2}$ of the maximum margined electrical load and greater than the total un-interruptible load. Under normal operation, two PCM-4s will be operational, each supplying power to one of the port / starboard longitudinal busses.
- PCM-1: Converts 1000 VDC Power from PCM-4 to 800 VDC power, 650 VDC Power, or another user-needed DC voltage. Also segregates and protects the Port and Starboard 1000 VDC Busses from in-zone faults. 650 VDC Power used to supply power to motor controllers for large motors and for large resistive heating applications. PCM-1 contains a number of modular Ship Service Converter Modules (SSCM) that can be paralleled to provide redundancy and the requisite power rating. Each SSCM currently has a rating of 300 kW and

uses a proprietary interface with the PCM-1 cabinet. SSCMs can provide power to segregated outputs. For each segregated output, with one SSCM out of service, the remaining SSCMs shall be able to supply the greater of 50% of the maximum margined load or 100% of the maximum margined un-interruptible load serviced by that segregated output. (The 2nd PCM-1 in the zone will supply the other 50% of the load)

- c. PCM-2: Converts 800 VDC power from PCM-1 into 450 VAC Power at 60 Hz. or 400 Hz. Although a zone may have multiple PCM-2s, cost savings can be realized by limiting the number of PCM-2s necessary to achieve survivability requirements. PCM-2 contains a number of modular Ship Service Inverter Modules (SSIM) that can be paralleled to provide redundancy and the requisite power rating. Each SSIM currently has a rating of 300 kW and uses a proprietary interface with the PCM-2 cabinet. SSIMs can provide power to segregated outputs. For each segregated output, with one SSIM out of service, the remaining SSIMs shall be able to supply the maximum margined load serviced by that segregated output.

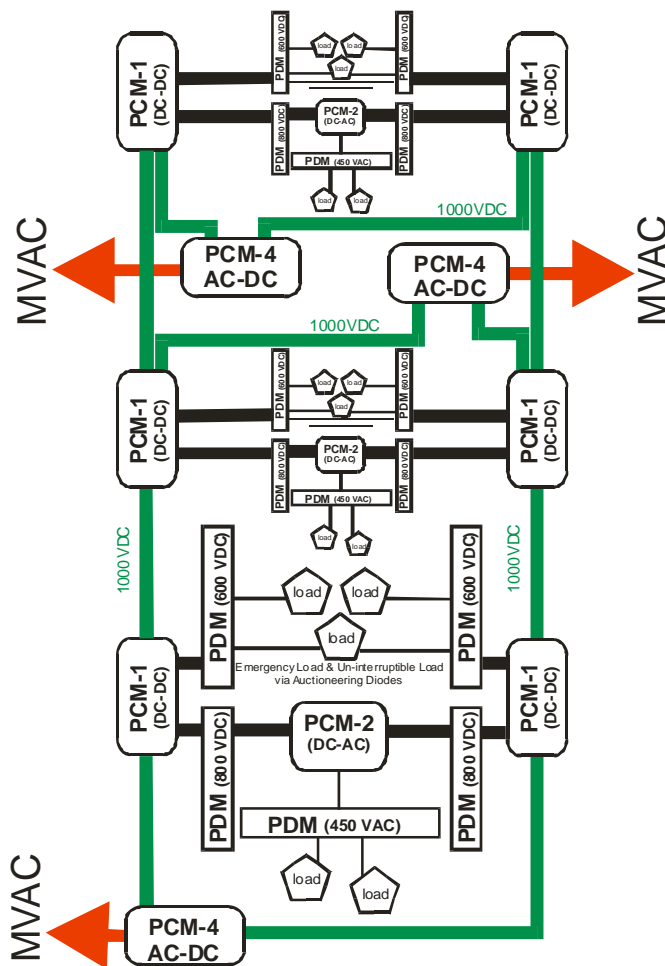

Figure 14: Current Generation IFTP

IFTP currently relies on traditional load centers, low power circuit breakers, and cabling to provide power to individual loads served by the PCM-1 (DC) and PCM-2 (AC). Also, the rating of devices assumes that a power system failure on the power generation bus will be detected, isolated, and power restored on both buses within 2 seconds.

If implemented properly, IFTP systems provide a high level of quality of service and survivability. Unfortunately, IFTP is also expensive. Figure 15 shows a potential future refinement of IFTP that replaces the current PCM-1 with a PCM-1A and PCM-2 with a PCM-2A. This refinement of IFTP enables a common approach to zonal electrical distribution for MVAC, HFAC and MVDC power generation. The functionality of the IFTP modules are modified as follows:

- a. PCM-4(A): Transformer Rectifier to convert MVAC/HFAC/MVDC power to 1000 VDC power. The functionality of the PCM-4 may be incorporated into PCM-1A.
- b. PCM-1A: A PCM-1A converts 1000 VDC Power from PCM-4 or power from MVAC/HFAC/MVDC to 750-800 VDC power, 650 VDC Power, another user-needed DC voltage, or 450 volt 60 Hz. AC Power. Also segregates and protects the Port and Starboard busses from in-zone faults. 650 VDC Power is used to supply power to motor controllers for large motors and for large resistive heating applications. For DC loads, PCM-1A contains a number of modular Ship Service Converter Modules (SSCM) that can be paralleled to provide redundancy and the requisite power rating. Similarly, for AC loads (short-term and long term interrupt 60 Hz. loads) PCM-1A contains a number of modular Ship Service Inverter Modules (SSIM) that can be paralleled to provide redundancy and the requisite power rating.
- c. PCM-2A: Converts 750-800 VDC power from PCM-1 into 450 VAC Power at 60 Hz., 400 Hz, or variable frequencies and voltages to drive variable speed motors. PCM-2A would be used to service un-interruptible AC loads as well as loads with special power requirements. The Integrated One notable difference from the current PCM-2 is that the PCM-2A would incorporate the features of a load center – individual loads, or sets of small loads, would have individual power converters. To enhance survivability, a zone could have multiple PCM-2As collocated with the serviced loads. In general, the number of loads serviced by PCM-2A should be minimized due to:
 1. The efficiency of the current generation air-cooled input and output modules for the PCM-2A is considerably less (~85%) than the efficiency of the water cooled PCM-1A (~ 97%)
 2. Since each of the output modules of the PCM-2A directly drives a load, N+1 redundancy is not provided. The reliability of the output modules of the PCM-2A will directly impact the QOS provided to loads.
 3. The cost of providing power to loads from PCM-1A will be less than the cost of providing power from PCM-2A via PCM-1A.

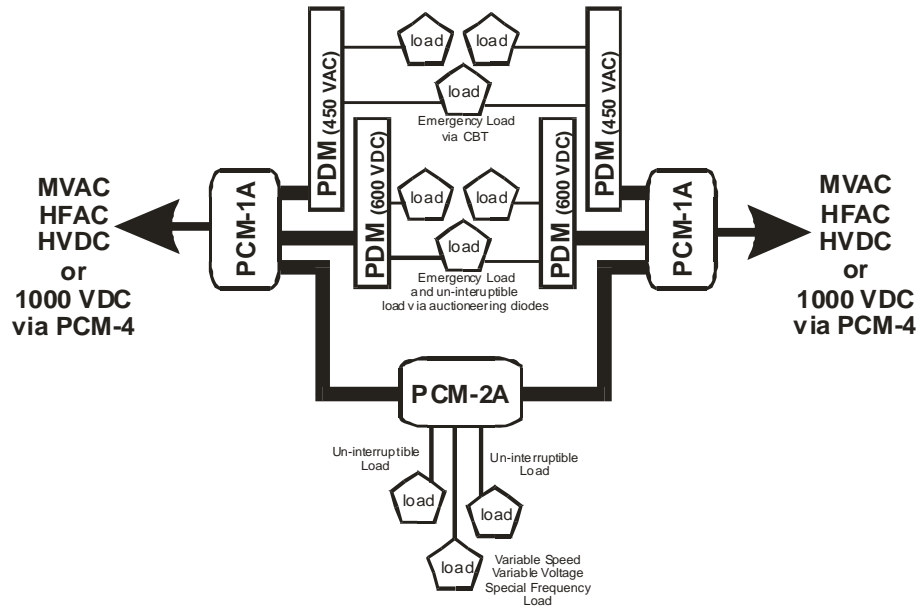

Figure 15: Potential Future IFTP in-zone architecture

Short-term and long term interruptible loads requiring two sources of 450 VAC power are provided power from the PCM-1As via a controllable bus transfer. This solution, while not un-interruptible, provides a more affordable means of providing the requisite level of survivability needed by a load. Similarly, DC loads requiring two sources of power are provided redundant sources from the PCM-1A via auctioneering diodes.

Some of the advantages of the proposed evolution of IFTP include

- The number of SSCMs is significantly reduced because SSCMs are not required to power SSIMS.
- By incorporating the functionality of PCM-4 into PCM-1A, only the high power system crosses zone boundaries, resulting in a reduction of cabling. Additionally, because the total capacity of all three PCM-4s is 150% of the maximum margined load, the distributed capacity of transformer rectification in the various PCM-1As is likely to be less. This is offset somewhat by the economy of scale in weight and cost of centralized transformers and rectifiers in the existing PCM-4s.
- By directly powering variable speed motors from the PCM-2A, a number of unique and dedicated motor drives can be eliminated from a ship design.

3.5 Power Generation Modules (PGM)

3.5.1 Gas Turbines

NGIPS anticipates the Navy will continue to use Aero derived gas turbines for marine applications. Technology to improve fuel efficiency is of great interest. Where practical the Navy intends to use common gas turbines across multiple classes of ships.

Of particular interest to the Navy is developing and qualifying for Navy use a fuel efficient, power dense, marine gas turbine with a full load rating of about 10 MW to fill the gap between the smaller 2-3 MW ship service gas turbines and the larger 20-40 MW gas turbines.

3.5.2 Diesel Engines

NGIPS anticipates that medium speed diesel generator sets will play an important role in providing fuel efficient propulsion plant configurations. Although much heavier than an equivalently power rated gas turbine, the improved fuel efficiency of the diesel engine can result in a substantial reduction in required fuel that can result in a ship with a lower full load displacement.

NGIPS anticipates a need for fuel efficient, power dense medium speed diesel engines with ratings in the 10-14 MW range that are suitable for naval applications.

NGIPS does not see a specific need to invest in diesel engine technology. The commercial marine industry will continue to drive developments in the marine diesel industry. The Navy should be prepared to invest in naval qualification of marine diesel engines.

NGIPS does see a need for continued R&D in shock tolerant sound isolation methods to reduce the acoustic signature of diesel engines.

3.5.3 Fuel Cells

Marine Fuel Cells have the potential to improve the fuel efficiency of naval warships while simplifying some ship integration challenges. The potential advantages of a Fuel Cell power generation module include:

- a. Theoretically more efficient than a diesel engine or gas turbine. The amount of increased efficiency of a practical fuel cell is somewhat diminished by the energy needed to convert logistics fuels such as Diesel Fuel Marine (DFM) or JP5 into the Hydrogen rich gas needed by the fuel cell, and by the need to scrub sulfur and sulfur compounds from the fuel. However, the first naval fuel cell systems will be competitive with present high efficiency diesels. This efficiency benefit has potential to increase to greater levels as technology matures.
- b. The amount of combustion air and exhaust gasses are significantly less than either a gas turbine or diesel. Offers the opportunity to employ the ship's ventilation system instead of dedicated intakes and uptakes. Architecturally, this enables fuel cell based PGMs to be located in the forward-most and aft-most zones, where their ability to provide redundancy for survivability is maximized.
- c. Fuel Cell design could conceptually be modularized to enable a scalable approach to achieve a needed PGM rating over the life of the ship. Service Life Allowance could be provided in the form of space, weight, and services, without providing the fuel cell capacity until actually needed by load growth. Ship acquisition programs need only buy what is needed at delivery, not what is projected to be needed at the end of the ship's service life.
- d. The reduced infrared signature of the Fuel Cell exhaust, as well as the lower acoustic signature will help reduce ship signatures.

Before a fuel cell can be integrated into a ship design, a number of challenges must be resolved:

- a. Fuel Reforming – Fuel Cells can not directly use the logistics fuels (DFM and JP-5) used by the Navy. A reformer is required to produce the hydrogen rich gas needed by the fuel cell. Additionally, any sulfur or sulfur compound must be scrubbed from the fuel. ONR continues to invest in reformer technology with the goal of developing a naval fuel reformer.
- b. Slow Dynamic Response – Fuel cell stacks operating by themselves are extremely responsive. However production of hydrogen gas from diesel fuel diminishes this responsiveness. Current state of the art stationary power fuel cells are presently constructed to operate with a commercial electrical grid and are designed to respond to changes in load with a time lag measured in seconds. A PGM must be able to respond to load changes in less than a tenth of a second. To solve this dynamic response mismatch, ONR is developing improved hydrogen gas reformers with increased responsiveness, hybridized systems design, and examining integration with energy storage.
- c. Slow Startup – State of the art Fuel Cells can require many minutes to startup. As a consequence, fuel cells are not normally considered for replacing emergency generators, but can be successfully employed as “base” power.
- d. Power Interface – Fuel Cells produce DC power, but not typically at a standard distribution voltage. Generally, fuel cells will require a power electronics conversion submodule to produce the power needed by the distribution system the Fuel Cell is connected.
- e. Power Density – Present commercial stationary power fuel cells, when coupled with their reformers and other auxiliary equipment, are considerably less power dense than gas turbines or diesels. This implies that the most likely initial application of a fuel cell would be on a ship with normal power density requirements. ONR developments for high power density fuel cell systems and reformers show potential for future fuel cell systems to be volume and weight competitive with present Navy gas turbine and diesel power generation modules.

3.5.4 High Speed Generators

The HFAC and MVDC propulsion bus options offer the opportunity to use power dense high speed generators for integration with high speed gas turbines and steam turbines. HFAC systems will likely employ either conventional synchronous machine designs, or use High Temperature Superconductor (HTS) rotor windings to improve power density and efficiency. The move to MVDC will also enable the use of high pole count permanent magnet (PM) generators. Controlled rectifiers would provide the voltage regulation for PM generators that the voltage regulating field current control provides in conventional and HTS generators. Generators for MVDC operation may be designed to operate efficiently over a range of speeds to enable maximizing the fuel economy of the prime mover. The development of high speed HTS and PM generators in S&T and R&D should continue.

Generators designed for HFAC operation can be effectively employed in a MVDC system with the addition of a rectifier. On the other hand, a generator –rectifier specifically designed for optimal

MVDC operation will likely not be effective for HFAC applications. The transition from HFAC to MVDC is one way.

3.5.5 Rectifiers and Inverters

Conventional rectifiers use either diodes or naturally commutating switches (such as Silicon Controlled Rectifiers – SCR) to convert AC power to DC. While inexpensive, this solution injects a considerable amount of current harmonics into the AC source which reduces power factor and can cause harmonics in the voltage waveforms. The lower power factor requires either the addition of power factor correction devices, or larger generators. To minimize the impact of current harmonics on voltage harmonics, the generator reactances must be reduced, which results in larger fault currents.

Additionally, the design of the rectifiers is greatly impacted by the implementation of fault detection and isolation. The rectifiers must be capable of withstanding the anticipated levels of fault current.

An alternative approach is to use the same type of switching devices used for inverters on the rectifier. While more expensive for the rectifier, this enables considerably lower current harmonics and near-unity power factor operation. Developing an affordable, Open Architecture, modular, and scalable active rectifier is desirable.

3.6 Propulsion Motor Modules (PMM)

3.6.1 Normal Power Density Propulsion Motors

NGIPS anticipates that current technology, such as the Advanced Induction Motor (AIM) employed by DDG-1000, is adequate and affordable for normal power density applications. The commercial marine industry is anticipated to drive future technological advancements in this area. The Navy is interested in improving part load efficiency of traditional motors. The Navy must still invest in design features for naval applications and testing to confirm adequate design.

3.6.2 High Power Dense Propulsion Motors

Surface combatants and submarines have a need for quiet, efficient, high power dense propulsion motors. Technologies such as AC Synchronous High Temperature Superconductor (HTS) motors or Permanent Magnet Motors offer the opportunity to provide the requisite propulsion motor power density. The basic viability of both technologies has been demonstrated. The open issues include:

a. The ability to scale designs with low risk to meet the specific needs of a ship application. The demonstrated motors are point designs for a specific power level and RPM. NGIPS is interested in industry developing a scalable product line for motors employing either HTS or PM.

b. The viability of the industrial base to support either HTS or PM based propulsion motor production. The relatively few motors that the Navy is likely to purchase in a given year will not support an industry. Industry production of PM and HTS motors for other customers is needed to reduce the risk and cost associated with the application of these technologies.

c. Engineering effort is needed to improve the affordability of power dense motors.

d. High efficiency over the full operating range of the propulsion motor is desired and will help reduce operational cost of the ship..

Direct Current, Low Temperature Superconducting (LTS) Homopolar motors are another possible technology for quiet power dense motors. In addition to the open issues detailed above, basic viability, durability and predictability of brush technology performance for homopolar machines is needed. ONR has an established program to understand the basic physics associated with the brush technology and also characterize the brush performance as it relates to full scale power LTS homopolar motors.

3.6.3 Motor Drives

Developing a common open architecture propulsion motor drive for multiple naval propulsion motor applications has the potential to improve NGIPS affordability and system performance. Features of such a drive would include:

a. Improved power density over existing commercial based drives. In many cases the volume required by a traditional motor drive exceeds the volume requirements of the propulsion motor.

b. Modular ability to interface with MVAC, HFAC, and MVDC power systems. Active rectification to eliminate the need for phase shifting transformers and to eliminate current harmonics is desired. Initially, the motor drive should be capable of interfacing directly to $\pm 4,000$ V d.c. systems and 4.16kV and 6.9 kV a.c. systems without the use of transformers using silicon based devices. The modularity should anticipate future introduction of Silicon Carbide switching devices and direct interface to 13.8 kV power generation systems and d.c. systems up to $\pm 10,000$ VDC..

c. Modular output stages to enable interfacing with motors with varying number of phases and power levels.

d. High efficiency from 5% of rated power through 100% of rated power.

e. Affordability to include the procurement cost of the drive, the cost to integrate and install the drive into a ship, and the operational and support costs over the ship's design life.

3.6.4 Advanced Propulsion

One of the advantages of electric propulsion is the opportunity to employ propulsion methods in warships other than the traditional twin shaft with open strut arrangement typically found in past surface ship design. Figure 16 for example, shows an alternate way to provide two independent propellers for redundancy, yet provide a propulsion efficiency advantage during normal operation. By employing a steerable podded propeller in contra rotation with a center line hull mounted propulsor, the propulsor realizes a significant increase in propeller efficiency (Generally estimated at about 10%), and a reduction in appendage drag through the elimination of open shafting and shaft struts. A 10% reduction in fuel consumption at the endurance condition has a significant impact in the amount of fuel the ship is required to carry.

While the use of pods has long been studied for naval applications, and is common practice in the commercial cruise ship industry, shock and acoustic performance at a significant power level has not been demonstrated to date. The configuration shown in Figure 16 has the advantage in that the podded power rating can be less than the hull mounted propulsor power rating. In this manner the risk of incorporating this type of drive in a ship design is reduced.

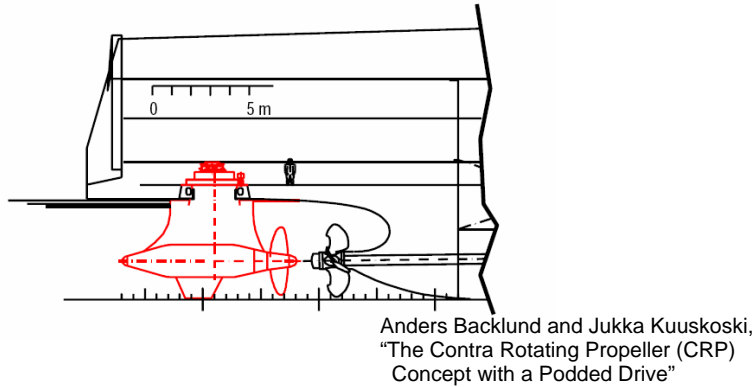

Figure 16 Contra Rotating Propeller with a Podded Drive

The Navy's recent Report to Congress on alternate propulsion indicated that longitudinally separating propulsion can significantly improve the vulnerability performance of a warship. An electrically driven forward propulsor capable of propelling the ship at a tactically useful speed reduces the likelihood of losing all propulsion power due to an underwater weapons detonation in the aft portion of the ship. As shown in Figure 17, forward propulsors are not new to the U.S. Navy and are currently used on FFG-7 class frigates. The auxiliary propulsion units on the FFG-7 class however, are not sufficiently sized to provide a tactically useful speed. Recent advances in power dense motor technology enable the development of a small, efficient and quiet retractable podded propeller in the 2000 to 5000 HP range.

The use of these advanced propulsor options is independent of the power system architecture selected for a given ship application. For the improvements in vulnerability, all future combatants should consider employing a forward propulsor. For risk reduction purposes, an Expeditionary Warfare Ship, Combat Logistics Ship or a Support Vessel may be an appropriate application for demonstrating the contra-rotating pod technology. Once demonstrated, application to a future surface combatant would be appropriate.

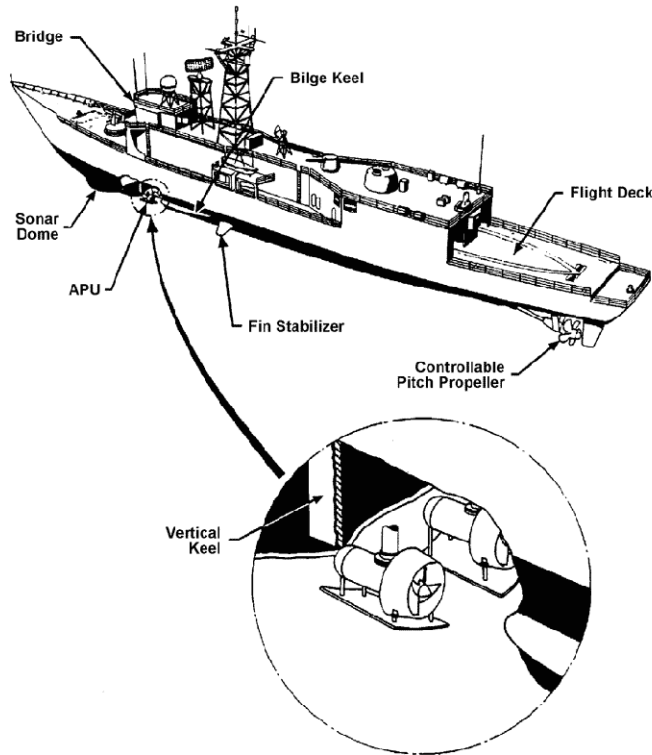

Figure 17 FFG-7 Auxiliary Propulsion Units

3.6.5 Hybrid Drives

A hybrid drive combines a mechanical drive prime mover with an electric motor. The electric motor can be mounted on the propulsion shaft as was done on the U.K. Type 23 frigate, or integrated with the mechanical drive reduction gear as was done on LHD 8. In the context of NGIPS, the greatest commonality and acoustic performance can be achieved with shaft mounted motors along with a clutch to detach the mechanical drive reduction gear. Integrating a motor in the reduction gear reduces the motor's size and weight, but at the expense of acoustic performance and commonality with other NGIPS ships.

Hybrid drives can be attractive if the maximum ship service electrical load over all speed ranges is substantial and nearly the same as the maximum ship service electrical load at maximum propulsion power. In a hybrid system, the mechanical drive prime movers should generally have a rating less than the difference between the maximum total ship power required at maximum propulsion power and the maximum total ship power required (including margin and service life allowance) at any speed up to endurance speed. The propulsion motor provides the cruise power while the mechanical drive diesel or gas turbine provides the boost power to achieve maximum speed. Such a hybrid system may prove more affordable than a full-IPS configuration (one where the propulsion motor provides all propulsion power) without compromising the power flexibility provided by IPS.

Hybrid drives are attractive only when the ship's missions require a high ship service load at very high speeds. Considerable savings in cost can be realized by not requiring high power mission loads

(such as high power radars and electro-magnetic guns) to operate at high speeds and employing a full-IPS configuration to route power to either propulsion or other mission system loads.

A variant of a hybrid drive is Propulsion Derived Ship Service (PDSS) where an electrical generator is integrated into the reduction gear of a mechanical drive ship. Power conversion is generally needed to convert the voltage and frequency of the variable speed generator to the voltage and frequency needed for power distribution. Because operational requirements may require a sudden drop in propulsion speed, PDSS designs must account for either the shaft stopping for fixed pitch propellers, or going to a minimum speed for controllable pitch propellers. In the case of fixed pitch propellers, the PDSS should not provide more power than the total amount of long-term interruptible loads. Rules for determining the extent that PDSS can account for total ship service power generation have not been established.

3.7 Power Load Module (PLM)

3.7.1 Categorizing and Amalgamating Loads

Design methods for estimating and characterizing loads into the QOS categories (Un-interruptible, short-term interrupt and long term interrupt) are needed. Additionally, standard methods for implementing QOS and mission priority load shedding are needed.

The current methods for amalgamating loads for sizing distribution system equipment were developed to support radial distribution systems. The applicability of these methods to zonal systems has not been evaluated. Alternatives include the use of zonal load factors, demand factors, and stochastic methods. A design guide / standard is needed to define the appropriate method(s) to use in Naval ship design.

3.7.2 Flexible Load Power Interface

The ability to cost effectively provide power to loads at a voltage and frequency that optimizes the load's performance, cost, and impact on the power system is of great interest to the Navy. For example, employing variable speed drives to motors in fluid systems and the HVAC system could improve system performance, reduce startup current transients, reduce energy consumption and improve motor reliability. To implement this capability requires the establishment of standards defining the portioning of controls and sensor responsibility among the PLM, PDM, and PCON.

There are many other examples where a flexible load interface would be useful. Aircraft derived systems often require 400 Hz. power. The ability to flexibly provide this type of power locally precludes the need to install a dedicated 400 Hz. power system. It may even become possible to eliminate specialized Aircraft Electrical Servicing Systems (AESS). Other mission systems may require DC power at specific voltages. Integrating foreign equipment may on occasion result in the need for 50 Hz. power at non-standard voltages.

3.7.3 Load Control Interface

The proper implementation of QOS and mission priority load shedding would be greatly facilitated by a control system interface standard for the PCON software to communicate with loads the need to turn off, reduce energy demand, or report future power needs. Implementing the control interface requires defining both physical and logical interfaces. In the near term the physical interface will likely be an existing protocol such as RS-232 or Ethernet. While this approach will work, the additional cabling and interface units can drive cost. In the future, dedicated control wiring

could be eliminated through the use of communication over power-line protocols such as the proposed IEEE P1901 for Broadband over Power Line Networks or wireless interfaces. Ideally the ability to support these protocols would be embedded as part of the load equipment controls. In the near term, an additional (common) interface unit may be employed to provide this capability. This interface unit may include an inexpensive smart switch to provide the ability of the PCON software to turn loads on or off.

3.7.4 Pulse Power Support

Future combat systems such as railguns, lasers, and high power radars may require large amounts of power in short pulses. Prime movers in general can not respond quickly enough to support these pulse power loads without assistance from energy storage. A typical power system for a railgun is shown in Figure 18. The Pulse Forming Network (PFN) draws power from the power system, stores the energy in either capacitors or in a rotating machine, then delivers the energy in a short burst. The size, complexity, and cost of the PFN will depend on how rapidly the PGMs can ramp up and down in delivered power.

High power, high energy storage for mobile pulsed applications is an emerging technical field. The conventional solutions have been capacitors for millisecond or shorter pulses and storage times, at full voltage, of less than about one minute, and rotating machines for fractions of a millisecond or longer pulses and storage times up to hours. Given the nature of the two storage systems, Navy, Army, and Air Force programs appear to be converging on rotating machines for longer pulse applications, like the Electromagnetic Aircraft Launch System (EMALS) and less-than-lethal weapons, and using a rotating machine to store the energy and discharge into a capacitor bank for shorter pulse applications.

As energy storage technologies mature, opportunities exist, if engineered properly, to use the same energy storage modules to serve pulse loads and to permit single-engine cruise operation (see Section 3.10) by providing backup power for uninterruptible and short-term interruptible loads. Engineering is also required to ensure the power and energy demands of the pulse power interfaces do not have a dynamic behavior incompatible with power system stability and power quality.

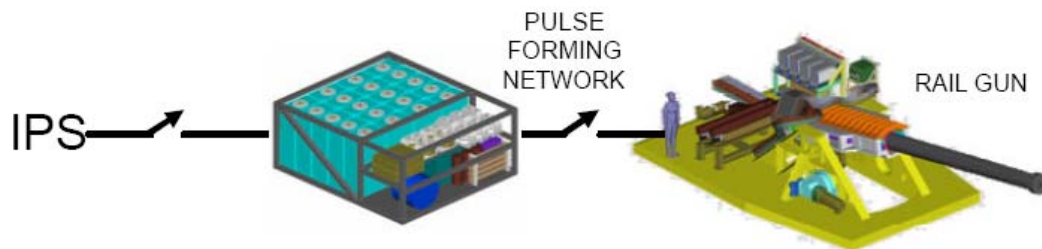

Figure 18: Notional Railgun Power Interface

3.8 Power Distribution Module (PDM)

3.8.1 Switchgear

Generally, MVAC systems will not require the development of new switchgear. Rather shock mounting of existing commercial switchgear will likely remain the preferred solution. HFAC systems require derating of switchgear designed for 60 Hz. The derating factors for switchgear and guidance for bus voltage require further study. Additionally, the impact of higher frequency operation on sensors, protective relays, switchboard controls, voltage regulators, and speed governors is not known. Some development of these components may be needed.

MVDC systems will require new switchgear. The requirements for these new switches will depend on the expected current interruption capability, both under normal and faulted conditions. Since the MVDC bus is expected to be powered by power electronics with fault protection algorithms, the switches should not experience fault currents an order of magnitude greater than rated conditions which is possible in MVAC and HFAC systems. MVDC systems may require the use of hybrid breakers where a mechanical switch is commutated with power electronics to eliminate the need to interrupt the direct current arc. Furthermore, MVDC distribution modules will require new sensors, protective relays, switchboard controls, and voltage regulation protocols.

3.8.2 Cable

Power cables for MVAC are non-developmental. Existing ship designs are using available cables or qualifying new cable designs. Analysis and testing of cables for HFAC operation are required to determine the appropriate rating for non-60 Hz. operation. Analysis and testing of cables for MVDC applications are needed to establish standards for military use of MVDC cables.

3.8.3 Load Control Interface

Conceptually, when power demand exceeds power generation capacity, the power system should be capable of shedding individual loads based on either QOS or mission priority needs. With control of individual loads, the power control module has maximum flexibility to optimize the QOS and mission priority load shed algorithms to the needs of the operational condition of the ship. Without the ability to control individual loads, different strategies must be employed to include:

- a. Install sufficient energy storage within a zone to provide power to short-term interrupt and un-interruptible loads for 5 minutes. Use traditional 2 or 3 stage fixed mission prioritized load shed buses if sufficient generation can not be restored in 5 minutes.
- b. For each of the traditional 2 or 3 stages of load shedding, break the bus into a short-term and long-term interrupt segments to enable initially shedding based on QOS, then on Mission Priority.

In both of the above strategies, some flexibility is lost because the QOS and Mission Priority of a load is fixed and not operationally sensitive. Additionally, because shedding is done by cutting power to loads without warning, the ability of loads to shut down in an orderly fashion is prevented. The introduction of a standard control interface between loads and the power interface would enable not only graceful shutdown of loads, but could enable loads to enter low power modes to maximize operational capability while still protecting the power system. Implementing the control interface requires defining both physical and logical interfaces. In the near term the physical interface will

likely be an existing protocol such as RS-232 or Ethernet. While this approach will work, the additional cabling and interface units can drive cost. In the future, dedicated control wiring could be eliminated through the use of communication over power-line protocols such as the proposed IEEE P1901 for Broadband over Power Line Networks or wireless interfaces. Ideally the ability to support these protocols would be embedded as part of the power conversion modules or distribution equipment.

3.8.4 Controllable Bus Transfer

Controllable Bus Transfers (CBT) enables a 440 VAC load requiring compartment survivability to have an alternate source of power restored to it following damage within a zone. A CBT differs from an Automated Bus Transfer (ABT) in that operation is not autonomous, but rather remotely controlled from PCON. PCON will not restore power to a load until a determination is made that powering the load is safe. Existing Solid State Automated Bus Transfer (SABT) devices are capable of performing the CBT function, but at considerable cost and excess capability. A cheaper solution may be to integrate two existing motor operated circuit breakers with a control unit and power supply into a CBT.

3.9 Power Conversion Module (PCM)

3.9.1 PCM-1A

Figure 19 shows a notional architecture for a PCM-1A which is an evolution of the PCM-1 in the current IFTP system. A PCM-1A converts 1000 VDC Power from PCM-4 or power from MVAC/HFAC/MVDC to 750-800 VDC power, 650 VDC Power, another user-needed DC voltage, or 450 60 Hz. AC Power. Also segregates and protects the Port and Starboard busses from in-zone faults. 650 VDC Power is used to supply power to motor controllers for large motors and for large resistive heating applications. For DC loads, PCM-1A contains a number of modular Ship Service Converter Modules (SSCM) that can be paralleled to provide redundancy and the requisite power rating. SSCMs can provide power to segregated outputs. For each segregated output, with one SSCM out of service, the remaining SSCMs shall be able to supply the greater of 50% of the maximum margined load or 100% of the maximum margined un-interruptible load serviced by that segregated output. (The 2nd PCM-1A in the zone will supply the other 50% of the load). Similarly, for AC loads (short-term and long term interrupt 60 Hz. loads) PCM-1A contains a number of modular Ship Service Inverter Modules (SSIM) that can be paralleled to provide redundancy and the requisite power rating. SSIMs can provide power to segregated outputs. For each segregated output, with one SSIM out of service, the remaining SSIMs shall be able to supply the maximum margined load serviced by that segregated output.

The architecture of PCM-1A should be modular and open. SSIMs and SSCMs should be available in different ratings to better match zonal demand. Ratings on the order of 35 kW, 100 kW, and 300 kW would provide a considerable amount of design flexibility to optimize reliability, cost, and efficiency. Further study is required to identify the optimal SSIM/SSCM ratings as well as the optimal internal bus voltage (notionally 1000 VDC shown in Figure 19).

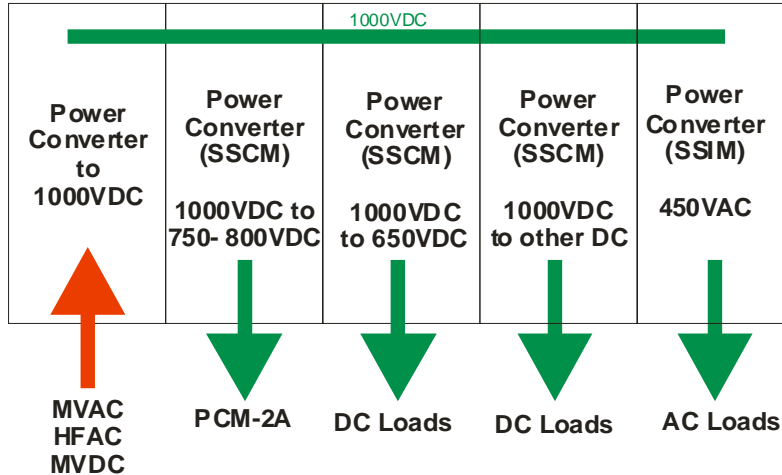

Figure 19: Notional PCM-1A Architecture

If system studies show that galvanic isolation is needed within the PCM-1A for system protection, then the incorporation of transformers capable of operation between 1 and 40 kHz. would be desirable to reduce size and weight. In this frequency range, traditional laminated cores would have high losses. Alternate materials such as nanocrystalline and amorphous metals have better properties, but require additional development.

3.9.2 PCM-2A

A PCM-2A is an evolution of the PCM-2 of the IFTP system. For HVDC and HFAC systems, it converts 750-800 VDC power from PCM-1 into 450 VAC Power at 60 Hz., 400 Hz, or variable frequencies and voltages to drive variable speed motors. PCM-2A would be used to service un-interruptible AC loads as well as loads with special power requirements. For MVAC applications, a PCM-2A could provide power to DC Loads. The notable difference from the current PCM-2 is that the PCM-2A would incorporate the features of a load center – individual loads, or sets of small loads, would have individual power converters. A PCM-2A enables the integration of variable speed drives into the power system for stand-alone motors. In this way, motors that are part of the HVAC system can be remotely controlled and their use optimized for efficiency. A draft performance specification (MIL-PRF-XX415) is currently under development for the Integrated Power Node Center (IPNC) which implements much of the functionality of the PCM-2A. The IPNC can seamlessly transfer input power from multiple power inputs of 750-800 VDC and/or 450 VAC. The input and output power modules described in the draft MIL-PRF-XX415 are listed in Table 6. To enhance survivability, a zone could have multiple PCM-2As collocated with the serviced loads. In general, the number of loads serviced by PCM-2A should be minimized due to:

- The efficiency of the air-cooled input and output modules for the IPNC is considerably less (~85%) than the efficiency of the water cooled PCM-1A (~ 97%). Over time, improvement in power electronics design should improve this efficiency.
- Since each of the output modules of the PCM-2A directly drives a load, or a moderate amalgamation of small loads, N+1 redundancy is not provided. The reliability of the output modules of the PCM-2A will directly impact the QOS provided to loads.

- The cost of providing power to loads from PCM-1A will be less than the cost of providing power from PCM-2A via PCM-1A.

Power Modules	Ratings (Ratings are based on maximum continuous current. Overload ratings are not required.)
Input Power Modules: 1. 440 V, 60 Hz, 3-phase 2. 750 V, DC	15 A, 30 A, 50 A, 100 A, 200 A, 400 A 50 A
Output Power Modules: 1. 440 V, 60 Hz, 3-phase (Adjustable for higher frequency – de-rating may be necessary) 2. 115 V, 60 Hz, 3-phase, 3-wire – MFPM (Adjustable for higher frequency – de-rating may be necessary) 3. 115/200 V, 60 Hz, 3-phase, 4-wire – MFPM (Adjustable for higher frequency – de-rating may be necessary) 4. 115 V, 3-phase fast switch modules 5. 375 V, DC 6. 120 V, DC	5 A, 15 A, 30 A, 50 A, 100 A, 200 A, 400 A 35 A, 60 A 25 A, 35 A, 50 A 10 A 15 A, 30 A 10 A, 20 A, 40 A, 60 A
From Draft MIL-PRF-XX415 INTEGRATED POWER NODE CENTER (IPNC).	

Table 6: Draft MIL-PRF-XX4315 IPNC Input and Output Modules for PCM-2A

3.9.3 60 Hz. Transformers

For most naval applications, the most affordable method for converting large amounts of 60 Hz. power from one voltage to another is through traditional Vacuum Pressure Encapsulated (VPE) transformers. VPE transformers can tolerate thermal cycling, moisture, salt air, dust, and industrial contaminants. VPE transformers are commercially available in ratings up to 13 MVA for Medium Voltage (4.16 to 13.8 kV) applications.

To improve voltage regulation, reducing the transformer’s reactance is desirable. Unfortunately, this also increases the in-rush current needed to magnetize the transformer core. Affordable methods to soft-start transformers are desired.

3.9.4 HFAC Transformers

For the frequencies of interest to HFAC power distribution, laminated iron transformer core technology used in 60 Hz. transformers will likely prove the optimum materials. The HFAC transformers operating at HFAC frequencies will be smaller & lighter than those designed for 60 Hz. The cross sectional area of a magnetic core of a transformer is approximately inversely proportional to the frequency of operation. Thus the weight of the transformer core (not

including the windings) of a 240 Hz. transformer would be expected to be about ¼ the weight of a 60 Hz. transformer that uses the same core material.

Because HFAC transformers are using the same technology as 60 Hz. transformers (although the laminations will likely be thinner), an established industrial base and design process already exists. Particular transformer designs must be tested and qualified for naval use.

3.9.5 Shore Power Interface

The shore infrastructure at naval facilities currently supports providing 3 phase 60 Hz. shore power at 450 volts. As the facilities are modernized, support for 4.16 kV and 13.8 kV 60 Hz. shore power is also being provided. A shore power interface at another voltage or frequency would require an investment in the shore infrastructure. Alternately, power conversion onboard ship could convert the power to that needed by the power generation system. For MVAC systems, the only voltage of concern is 6.9 kV. This can be accommodated by modifications to the shore infrastructure, by providing a dedicated shore power transformer / autotransformer, or by providing additional taps on the primary of two or more zonal transformers to enable a 4.16 kV connection.

A shipboard interface to HFAC or MVDC would require a power conversion module. Since the shipboard interface would appear to shore power as a constant power load, consideration must be made to ensuring the shore power system remains stable. An interface to MVDC may be as simple as a controlled rectifier – if the shore power infrastructure can tolerate the current harmonics. If not an active rectifier may be needed. An HFAC system would likely require a rectifier followed by an inverter stage. A high frequency transformer may also prove advantageous.

3.10 Energy Storage Modules (ESM)

Given sufficient flexibility in the selection of prime movers for an IPS configuration, an energy storage module is not required to provide quality of service or survivability for ships without Pulse Power loads. In certain design situations however, incorporating an energy storage module may prove economical.

An Energy Storage Module (ESM) can be based on a host of technologies to include batteries, flywheels, Superconducting Magnetic Energy Storage (SMES), and ultra-capacitors. Energy Storage modules will often include significant power conversion electronics to interface with the Power Distribution Module. The power rating and energy capacity of an ESM will depend on the intended application that will usually fall into one of the following categories:

- Low Power (~250 KW) for 2 to 10 seconds: Provide hold-up power to uninterruptible loads while traditional electro-mechanical switchgear isolates faults. Also protects uninterruptible loads from normal system transients. For this application, the Energy Storage Module should be distributed and physically near the serviced loads.

- Medium Power (~500 KW) for 5 to 10 minutes: Provide hold-up power for uninterruptible and short term interruptible loads to enable single PGM cruise operation or operation with multiple small PGMs near their maximum rating. The ESM provides power while a standby

PGM starts should an online PGM shut down unexpectedly. For this application, either centralized or distributed Energy Storage Modules would be suitable.

- Low Power (~250 KW) for 15 to 30 minutes: Provide emergency starting for PGMs in a dark ship condition. For this application, ESMs collocated with the PGMs is optimal.

- High Power (~30 MW) for seconds: Provide load leveling for pulse power loads such as rail gun Pulse Forming Networks (PFN), high powered lasers, and advanced radars. ESMs could also improve transient response of fuel cells. For this application, either collocation with the PGMs or the pulse power loads would be appropriate. Further study is needed to determine the optimal location.

- High Power (~30 MW) for 5 minutes: Provide standby power for pulse power loads such as rail gun Pulse Forming Networks (PFN), high powered lasers, and advanced radars. Provide power to PFN while standby generator is brought on line. For this application, collocation with the pulse power loads would be appropriate.

Although the advantages of an ESM are known and batteries are a standard feature of submarine power systems, a shipboard qualified ESM for surface ship use has not yet been developed. Ideally, a single ESM architecture employing common and scalable hardware and software elements could be employed to meet all of the above categories.

3.11 Power Control Module (PCON)

The Power CONTROL module (PCON) consists of the software necessary to coordinate the behavior of the other modules. The PCON Software may reside in other modules, or may reside in an external distributed computer system. The PCON Software interacts with the human operators through a Human-Computer Interface that will typically be part of a ship-wide monitoring and control system. The primary functions of the PCON software are

- a. Remote Monitoring and Control of NGIPS modules
- b. Mobility Control
- c. Resource Planning, System Configuration and Mission Priority Load Shedding
- d. Fault Detection , Fault Isolation, QOS Load Shedding
- e. Maintenance Support
- f. Training

While the Power Control Modules are software, survivability and Quality of Service requirements impact the design of the hardware network the Power Control Modules will reside on. Survivability and QOS also influence the partitioning and redundancy of the software implementation of the Power Control Modules. The Power Control Module should facilitate maintenance of the various IPS Modules. Ideally electrical isolation and tagouts would be implemented or at least facilitated by features in the Power Control Module. Special operating modes of IPS Modules may be required for conducting condition monitoring tests, preventative maintenance, and corrective maintenance. The Power Control Modules should be developed to easily maintain over its lifecycle.

To date, controls for IPS systems have been developed as part of the ship-wide control system. No explicit effort has been made to develop a common PCON software for multiple classes of ship. To promote commonality of software across the fleet, an Open Architecture approach for NGIPS PCON should be implemented. Ideally, the software should be self-configuring, or require a minimum of configuring when installed onboard any one ship. To a certain degree, system level control algorithms are independent of architecture selection. Exceptions include:

- a. A.C. systems must regulate both real and reactive power, D.C. system only regulate real power.
- b. MVDC systems must explicitly address stability due to the negative incremental resistance of the power electronic driven loads. HFAC systems must also address stability, but to a lesser degree.
- c. Fault detection and Isolation for MVDC will differ significantly from MVAC or HFAC implementations.

3.12 Systems Architecting and Engineering

To successfully develop and maintain the NGIPS technical and systems architectures, a number of overarching capabilities and resources are needed. For example, because commonality across the fleet of components is a potential affordability driver, understanding how the fleet will evolve over a fifty year time horizon is critically important. Because it is impossible to predict what the fleet will look like in fifty years, the best we can do is develop a set of alternate future fleet force architectures that hopefully will bound what actually will be built. These alternate future fleet force architectures, and their derived energy usage profiles, will indicate where commonality is important, and where technological improvements are needed to achieve mission capability and reduce life-cycle cost.

The development of a common requirements language to translate the needs of the operator into affordable systems is needed.

Another need is for the development and maintenance of reference power system designs, including uncertainty analysis, to support ship concept studies. By using tailorable reference power systems for which weight, volume, and cost prediction algorithms have been refined, the accuracy of ship concepts can be significantly improved. For the cost algorithms, a product oriented cost model for NGIPS, including uncertainty analysis, would facilitate system optimization.

Energy usage, reliability and maintainability, as well as manpower requirements all are based on how the machinery plant is assumed to operate. A published reference machinery system concept of operations that can serve as a template for individual ship concepts can serve to ensure energy usage, lifecycle costs, and manpower requirements are all employing the same concept of operations for analysis purposes.

A validated and verified Simulation Environment with associated dynamic models is needed to support preliminary and contract design of NGIPS systems, interface specification

development, as well as integration studies with special loads (i.e. pulse power). Additionally, methods and data to quantify Quality of Service performance are needed.

Other ongoing tasks include identifying and tracking NGIPS risks, as well as knowledge management. Knowledge Management includes maintaining a Virtual Technical Library of configuration managed final documents, specifications, standards, test reports, test data, and maintenance records. Also needed are the configuration managed LEAPS product models of NGIPS modules and components.

(This Page Left Intentionally Blank)

4 TECHNOLOGY INSERTION AND ENGINEERING ROADMAP

For the purpose of this Technology Insertion and Engineering Roadmap, three different time deadlines are defined to indicate when a technology or design documentation should be ready for incorporation into a ship design. The three time deadlines are:

Deadline A: Ending in 2010, represents efforts needed to complete to support the design of a near term CG(X).

Deadline B: Ending in 2014, represents efforts needed to support forward fit of technology into submarines and potentially later 2nd generation CG(X).

Deadline C: Ending in 2018, represents efforts needed to support new design amphibious warfare ships, auxiliary ships, DDG(X) and a future new design SSN. Also efforts needed to support Pulse Power weapons.

Technology should achieve a Technology Readiness Level (TRL) 6 by the Deadline. TRL 6 is described as a “Representative model or prototype system, which is well beyond that of TRL 5, is tested in a relevant environment. Represents a major step in a technology’s demonstrated readiness. Examples include testing a prototype in a high-fidelity laboratory environment or in simulated operational environment.” For IPS systems, successful full scale demonstration as part of an integrated system at a Land Based Test Site such as NAVSSES Philadelphia is assumed to suffice to achieve TRL 6.

While the Deadline indicates the end date for development of a technology or design documentation, the start date will depend on the effort required and available funding. Because of the complexity of a number of the technical risk areas, work on a number of Deadline C activities should commence as soon as possible. A more detailed breakout of activities is included in Appendix E.

The dates associated with each deadline will likely change as the thirty year shipbuilding plan and ship acquisition strategies evolve.

4.1 Medium Voltage AC Power (MVAC)

MVAC-1: Develop and/or update standards, design data sheets, design tools, and design data to provide consistency in design across ship classes.

4.2 High Frequency AC Power (HFAC)

HFAC-1: Develop and/or update standards, design data sheets, design tools, and design data. to provide consistency in design across ship classes.

Deadline A:

None

Deadline B:

HFAC-B1: Establish an equipment qualification facility and associated processes/methods.

HFAC-B2: Develop and demonstrate HFAC system stability and bus overvoltage stability standard. Document in a design standard.

HFAC-B3: Demonstrate and test a Full Scale demonstration of an HFAC system.

Deadline C:

None

4.3 Medium Voltage DC Power (MVDC)

MVDC-1: Develop and/or update standards, design data sheets, design tools, and design data to provide consistency in design across ship classes.

Deadline A:

None

Deadline B:

None

Deadline C:

MVDC-C1 Develop and demonstrate System Fault Detection and Isolation methods. Document in a design standard.

MVDC-C2 Develop and demonstrate MVDC system stability and bus overvoltage stability standard. Document in a design standard.

MVDC-C3 Develop and demonstrate a system grounding and galvanic isolation method. Document in a design standard.

MVDC-C4 Develop an MVDC Test Infrastructure

MVDC-C5 Develop MVDC System Integration Methods. Document in a design standard.

MVDC-C6 Demonstrate and test a Full Scale demonstration of an MVDC system.

4.4 Zonal Electrical Distribution Systems (ZEDS)

ZEDS-1: Develop and/or update standards, design data sheets, design tools, and design data. to provide consistency in design across ship classes.

Deadline A:

ZEDS-A1: Develop and document a method for amalgamating loads for sizing distribution system equipment.

ZEDS-A2: Develop and document a method for characterizing and estimating loads by QOS category and survivability category.

ZEDS-A3: Develop and document a control system interface standard for NGIPS to communicate with loads to enable flexible load shed and load management strategies. Interface standard should include physical, electrical, and logical interfaces.

ZEDS –A4: Conduct a study to determine which methods are most affordable for achieving QOS requirements.

Deadline B:

ZEDS-B1: Demonstrate and test a Full Scale demonstration of IFTP system employing PCM-1A, PCM-2A, and if necessary, a new PCM-4.

Deadline C:

ZEDS-C1: Demonstrate and test a Full Scale demonstration of IFTP system employing improved efficiency PCM-2A power modules and communications over the power line.

4.5 Power Generation Modules (PGM)

Deadline A:

- PGM-A1: New higher power ATG based on high frequency AC generation with power electronics to produce 60 Hz. Power to support near term CG(X). New PGM must fit in same footprint as existing ATG on DDG-1000.

Deadline B:

- PGM-B1: Develop and document a method for paralleling of HFAC generators.
- PGM-B2: Develop 4-10 MW generator for 1800 rpm operation suitable for MVDC applications and if necessary, HFAC operation
- PGM-B3: Develop 20 to 40 MW scalable generator for 3600 rpm operation suitable for MVDC applications and if necessary, HFAC operation
- PGM-B4: Develop 4-10 MW scalable generator for 7200 rpm operation suitable for MVDC applications and if necessary, HFAC operation
- PGM-B5: Develop scalable generator for steam turbine operation suitable for MVDC applications and if necessary, HFAC operation
- PGM-B6: Develop scalable rectifier for MVDC applications.

Deadline C:

- PGM-C1: Develop and/or update standards, design data sheets, design tools, and design data to provide consistency in the design and integration into ship designs of power systems employing Fuel Cell Power Generation Modules.
- PGM-C2: Develop and Demonstrate at full scale, a modular and scalable fuel cell that can employ Navy logistics fuels and produce power with the power quality and dynamic response needed by the NGIPS distribution modules.

4.6 Propulsion Motor Module (PMM)

Deadline A:

- PMM-A1: New Propulsion Motor and Drive based on either permanent magnet motor technology or advanced superconducting technology to interface on MVAC to support near term CG(X).

Deadline B:

- PMM-B1: Develop a design standard and guidance for integrating electric propulsion motors with mechanical drive prime movers.
- PMM-B2: Develop and/or update standards, design data sheets, design tools, and design data. to provide consistency in the design of forward propulsors across ship classes
- PMM-B3: Develop and demonstrate a quiet, shock hardened, efficient retractable forward pod capable of propelling a ship at a tactically useful speed.

Deadline C:

- PMM-C1: Develop and/or update standards, design data sheets, design tools, and design data. to provide consistency in the design of aft podded propulsors as a part of contra-rotating propulsion systems.
- PMM-C2: Develop and demonstrate an aft steerable podded propulsion as part of contra-rotation for improved efficiency. First application should target combat logistics force ship.
- PMM-C3: Develop affordable methods to reduce Propulsion Motor Drive induced current harmonics without using 60 Hz. transformers. Possible methods include active rectification and advanced filters.
- PMM-C4: Develop an open architecture motor drive common across ship classes.

4.7 Power Load Module (PLM)

Deadline A:

None

Deadline B:

None

Deadline C:

- PLM-C1: Develop and/or update standards, design data sheets, design tools, and design data to provide consistency in the design of power systems to support Pulse Power applications.
- PLM-C2: Demonstrate support for Pulse Power applications at full scale.

4.8 Power Distribution Module (PDM)

Deadline A:

PDM-A1 Develop and qualify a controllable bus transfer (CBT) for use in ZEDS

Deadline B:

PDM-B1: Develop derating guidance and/or test procedures for switchgear operating at HFAC.

PDM-B2: Develop derating guidance and/or test procedures for cables operating at HFAC.

PDM-B3: Develop and qualify for naval use distribution system instrumentation operating at HFAC.

PDM-B4: Develop and document cable installation methods for operation at HFAC.

Deadline C:

PDM-C1: Develop and qualify for naval use affordable MVDC switchgear

4.9 Power Conversion Module (PCM)

Deadline A:

Deadline B:

PCM-B1: Develop and test an open architecture and scalable Shore Power interface that can interface with either an HFAC or MVDC power distribution system.

PCM-B2: Develop and demonstrate PCM-1A as an open architecture module suitable for surface ship and submarine applications.

PCM-B3: Develop and demonstrate PCM-2A as an open architecture module suitable for surface ship and submarine applications. Base the PCM-2A on the IPNC performance specification.

PCM-B4: Determine and document whether incorporating PCM-4 functionality into PCM-1A or keeping a centralized PCM-4 (current design) is the preferred architecture for interfacing with MVAC, MVDC, and HFAC power

generation systems. If necessary, develop and demonstrate a PCM-4 able to interface with HFAC and/or MVDC.

Deadline C:

- PCM-C1: Develop and test affordable methods to reduce acoustic signature and vibration of 60 Hz. Power Transformers.
- PCM-C2: Improve the efficiency of the PCM-2A power modules.
- PCM-C3: Integrate communications over the power line into the PCM-2A power output modules. Consider the use of IEEE P1901 for Broadband over Power Line Networks.
- PCM-C4: Integrate communications over the power line into the PCM-1A SSIMs and SSCMs.
- PCM-C5: Develop a standard load interface unit to enable loads to employ communications over the power line for machinery control applications.

4.10 Energy Storage Module (ESM)

Deadline A:

- ESM-A1: Study and Report if an ESM can contribute to ship affordability
- ESM-A2: If affordable, Develop and Document an open architecture approach for ESM Development
- ESM-A3: If affordable, Develop and Test an ESM (Possibly defer to Deadline B)
- ESM-A4: Develop and/or update standards, design data sheets, design tools, and design data to provide consistency in the design of power systems employing Energy Storage Modules. (Possibly defer to Deadline B)

Deadline B:

None

Deadline C:

- ESM-C1: Develop and/or update standards, design data sheets, design tools, and design data to provide consistency in the design of power systems employing Energy Storage Modules for Pulse Power support that can also enable single engine cruise operation.

ESM-C2 Develop and Demonstrate at full-scale, an intermediate energy storage solution for Pulse Power applications that can also enable single engine cruise operation.

4.11 Power Control Module (PCON)

PCON-1: Develop and/or update standards, design data sheets, design tools, and design data to provide consistency in the design of power control modules for IPS.

Deadline A:

PCON-A1: Develop and Document a PCON open architecture

PCON-A2: Develop and demonstrate an open architecture PCON software implementation to support MVAC, HFAC, and ZEDS that includes the following functionality:

- a. Remote Monitoring and Control of NGIPS modules
- b. Mobility Control
- c. Resource Planning, System Configuration and Mission Priority Load Shedding
- d. Fault Detection , Fault Isolation, QOS Load Shedding

Deadline B:

PCON-B1: Develop and demonstrate an open architecture PCON software implementation to support MVAC, HFAC, and ZEDS that adds the following functionality:

- e. Maintenance Support
- f. Training

Deadline C:

PCON-C1 Extend and demonstrate an open architecture PCON software implementation to additionally support MVDC.

4.12 Systems Architecting and Engineering

SYSE-1 Develop and maintain alternate future fleet force architectures to support commonality studies for years 2030, 2045, 2060, and 2075. Derive energy usage profiles, including uncertainty analysis, for each alternate fleet.

SYSE-2 Develop and maintain reference power system designs, including uncertainty analysis, to support ship concept studies.

- SYSE-3 Develop and maintain a product oriented cost model for NGIPS systems that incorporates uncertainty analysis.
- SYSE-4 Develop and maintain a reference machinery system concept of operations.
- SYSE-5 Develop and maintain a validated and verified Simulation Environment with associated dynamic models to support preliminary and contract design of NGIPS systems, interface specification development, as well as integration studies with special loads (i.e. pulse power).
- SYSE-6 Identify and Track NGIPS risks
- SYSE-7 Develop and Maintain a NGIPS knowledge management system

(This Page Left Intentionally Blank)

5 CONCLUSIONS & RECOMMENDATIONS

The Next Generation Integrated Power System is focused on implementing an Open Architecture Business and Technical model. The NGIPS OA Business Model segregates the tasks of determining required capabilities, ship system engineering, architecting, module development, systems integration, and life cycle support. The NGIPS Technical Architecture consists of four sets of standards for different applications:

- a. Medium Volt AC Power (MVAC) – For ships not requiring high power density.
- b. High Frequency AC Power (HFAC) – Interim solution for ship applications requiring high power density.
- c. Medium Voltage DC Power (MVDC) – Goal for ship applications requiring high power density; more compactly enables high power demanding electric mission loads.
- d. Zonal Electrical Distribution Systems (ZEDS) – For all ship applications.

For ships not requiring high power density, the MVAC Power system will continue to provide the most affordable solution for power generation and ship-wide distribution. Within the 30 year shipbuilding plan, the likely candidates for MVAC power would include future designs for Expeditionary Ships, Combat Logistics Ships, and Support Vessels.

The goal for NGIPS includes the implementation of MVDC Power for ships requiring high power density such as surface combatants and submarines. Significant technical risks preclude a near term application of MVDC. As a risk mitigation step to MVDC, a HFAC system consistent with a transition to MVDC is the preferred alternative for near term high power dense applications.

The power system architecture for CG(X) will be determined during its preliminary design. Depending on the acquisition strategy, available design time, and commonality with DDG-1000, the CG(X) power systems architecture will likely be either an evolutionary change from the DDG-1000 IPS design, or conform to the architectures and technologies in this NGIPS roadmap.

The Zonal Electrical Distribution System design should evolve to provide a more affordable open architecture solution to meeting power system power quality, quality of service, and survivability requirements of the zonal loads for both surface ships and submarines. In particular, PCM-1 should evolve into an open, modular architecture PCM-1A that incorporate both SSIMs and SSCMs. Likewise, evolve the IPNC performance specification into an improved PCM-2A. Also, the Navy should develop a CBT, a control interface to loads, and design methods and standards to implement ZEDS. Studies should also determine whether centralized PCM-4s as currently incorporated in IFTP, or incorporating PCM-4 functionality into PCM-1A is the preferred solution for MVAC, HFAC, and MVDC power generation systems.

If cost effective, ship designs should consider hybrid mechanical and IPS designs. Hybrid drives may be beneficial if high mission loads are required simultaneously with maximum propulsion power. If the simultaneous mission power and propulsion power requirement is

relaxed, a more affordable full-IPS is likely possible. To enhance commonality with other NGIPS implementations, hybrid designs should consider shaft mounted motors vice reduction gear mounted motors.

In certain cases, Propulsion Derived Ship Service power generation where a variable frequency generator is integrated into a mechanical drive reduction gear may prove attractive to reduce fuel consumption. Additionally, integrated generators with suitable energy storage is a feasible way to allow single, ship service generator operations which also results in reduced fuel consumption and lower operating hours on the installed generators.

To improve the survivability of the mobility mission area, the Navy should develop and deploy a forward retractable podded propulsor in future warships. Longitudinal separation of propulsors has been shown to significantly decrease the vulnerability of the mobility mission.

To improve fuel efficiency, the Navy should consider developing and deploying on the next applicable new design Expeditionary Ship, Combat Logistics Ship, or Support Vessel, an aft centerline steerable podded propulsor operating in contra-rotation with a hull mounted centerline shaft and propeller.

To promote fleet commonality, reduce integration risk, and promote affordability, the Navy should develop and evolve an open architecture Power Control (PCON) Module. The initial set of software should focus on:

- a. Remote Monitoring and Control of NGIPS modules
- b. Mobility Control
- c. Resource Planning, System Configuration and Mission Priority Load Shedding
- d. Fault Detection , Fault Isolation, QOS Load Shedding

Over time, the PCON software should incorporate maintenance support and training functionality.

The Navy should develop an open architecture Energy Storage Module and apply it to ship applications when proven economical. The Navy should evolve the ESM into having the capability to serve as intermediate energy storage for pulse power applications.

Overarching all technical advances, the Navy should emphasize the development and maintenance of standards, design data sheets, design tools, and design data. These documents are crucial to achieving the benefits of an open architecture and commonality across the fleet.

6 Bibliography

Amy, LCDR J.V. Jr., LCDR N. H. Doerry, LCDR T. J. McCoy, and Dr. E. L. Zivi, "Shipboard Controls of the Future", Naval Engineers Journal, May 1997.

Amy, John, "Modern, High-Converter-Populations Argue for Changing How to Design Naval Electric Power Systems," presented at IEEE Electric Ship Technologies Symposium, July 25-27, Philadelphia, PA.

Apriainen, Matti, Kimmo Juurmaa, Kari Laukia, Mikko, Niini, Kauko Jarvinen, Peter Noble, "Naval Architecture of Electric Ships--Past, Present and Future", Presented at the SNAME Centennial Meeting, September 14-19, 1993. New York City

Backlund, Anders, and Jukka Kuuskoski, " The Contra Rotating Propeller (CRP) Concept with a Podded Drive ," Motor Ship Conference, Amsterdam, March 28-29, 2000.

Brick, Darren C., Paul E. Jordan, Dale N. Pegram, John K. Taylor, Mathew Kasson, John Shegirian, and Gregory D. Stevens, "Engineering Report – Shipyard Team Review of Next Generation Integration Power System Architectures," Northrop Grumman and General Dynamics, Contract N00024-06-C-4202TI#007, Report NGIPS/TR-09-07/001 of Sept 28, 2007.

Broughton, E., Langland, B., Solodovnik, E. And Croft, G "Virtual Test Bed User's Manual," University of South Carolina, <http://vtb.ee.sc.edu/>, August 27, 2004.

Curtis-Wright Electro-Mechanical Corporation (EMD), "High Frequency Gas Turbine Driven Main Generator for Surface Ship Integrated Power System Application," White Paper dated April 21, 2006, Cheswick, PA.

Dalton, Thomas, Abe Boughner, C. David Mako, and CDR Norbert Doerry, "LHD 8: A step Toward the All Electric Warship", presented at ASNE Day 2002.

Dankers, G. A., Jr., "U.S. Navy Surface Ship Speed-Power Relationships," Bureau of Ships Preliminary Design Branch, 27 March 1961.

DeMarco, Tom, "On Systems Architecture," Proceedings of the 1995 Monterey Workshop on Specification-Based Software Architectures, U.S. Naval Postgraduate School, Monterey, California, September 1995, <http://www.systemsguild.com/GuildSite/TDM/Architecture.html>.

Department of Energy, Office of Field Management, Office of Project and Fixed Asset Management, "Reliability, Maintainability, Availability (RMA) Planning", Good Practice Guide GPG-FM-004, March 1996.

DOD-STD-1399 Section 301A "Ship Motion and Attitude " of 21 July 1986.

Doerry, LCDR Norbert and LCDR James C. Davis, " Integrated Power System for Marine Applications", Naval Engineers Journal, May 1994.

Doerry, LCDR Norbert, Henry Robey, LCDR John Amy, and Chester Petry, "Powering the Future with the Integrated Power System", Naval Engineers Journal, May 1996.

Doerry, CAPT Norbert, "Zonal Ship Design", presented at the ASNE Reconfiguration and Survivability Symposium, February 16-17, 2005, Atlantic Beach FL.

Also published in ASNE Naval Engineers Journal, Winter 2006, Vol. 118 No 1, pp 39-53.

Doerry, CAPT Norbert H. and David H. Clayton, "Shipboard Electrical Power Quality of Service", 0-7803-9259-0/05/\$20.00 ©2005 IEEE, Presented at IEEE Electric Ship Technologies Symposium, Philadelphia, PA, July 25-27, 2005.

Doerry, CAPT Norbert H., "Systems Engineering and Zonal Ship Design," presented at the ASNE Engineering the Total Ship Symposium, ETS 2006, May 1-2, 2006.

Doerry, CAPT Norbert H. and Howard Fireman, "Designing All Electric Ships," Presented at IMDC 2006, Ann Arbor, Michigan, 16-19 May 2006.

Doerry, CAPT Norbert H., "Institutionalizing the Electric Warship," presented at ASNE EMTS 2006, Philadelphia, PA, May 22-24, 2006.

Also published in ASNE Naval Engineers Journal, 2006, Vol. 118 No 4, pp 57-64.

Doerry, CAPT Norbert H., "Sizing Power Generation and Fuel Capacity of the All-Electric Warship" presented at IEEE ESTS 2007, Arlington, VA, May 22-23, 2007.

Doerry, CAPT Norbert, " Designing Electrical Power Systems for Survivability and Quality of Service" presented at ASNE DAY 2007, Arlington, VA, June 25-26, 2007.

Doyle, Timothy, Howard Stevens, and Henry Robey, " An Historical Overview of Navy Electric Drive ," circa 2003

Dusang, Louis V. Jr., P.E., "Makin Island Auxiliary Propulsion System: Ship-fit Challenges of Electric Propulsion," presented at ASNE Day 2005, April 26-27, 2005, Virginia Beach Pavilion, Virginia Beach, VA.

Hane, Thomas H., Elizabeth Gauthier, Scott W Lang, and Tracy Joseph Valsi, "Modularity in HM&E Systems," *Naval Engineers Journal*, v. 107, n.3, May 1995, pp. 149-166.

Henderson, Nancy, Swarn Kalsi, Bruce Gamble, and Greg Snitchler, " Performance of a 5 MW High Temperature Superconductor Ship Propulsion Motor ," presentation to Ship Tech 2005.

Hockney, Richard, and Matthew Polimeno, " Flywheel Energy Storage for Shipboard Zonal Power," AES 2005.

Huang, Kai, "Shipboard Power System Reconfiguration Using Multi Agent System," Ph.D. Dissertation for Florida State University, Summer Semester 2007.

Jatskevich, J., O. Wasynczuk, N. Mohd Noor, E. A. Walters, C. E. Lucas, and P.T. Lamm, "Distributed Simulation of Electric Power Systems," 14th PSCC, Sevilla, 24-28 June 2002, Session 33, Paper 2.

Littlefield, Scott, " Advanced Capability Electric Systems ," Presentation to NDIA Disruptive Technologies Conference, September 2006.

Mecrow, B.C. and A. G. Jack, " Efficiency Trends in Electric Machines and Drives ," University of Newcastle Upon Tyne, circa 2006

NATO NIAG NG6-SG/4, "Electric Warship Technology, NIAG/SG61 Pre-Feasibility Study," AC141(NG6)D/28, AC141(NG6-SG4)D/15, NIAG-D(2001)5.

Naval Sea Systems Command, "ESTABLISHING THE NEXT GENERATION INTEGRATED POWER SYSTEM BASELINE ARCHITECTURE," SEA 05DB memorandum Ser 05D/154 of 29 May 2007.

Naval Sea Systems Command, "Military Standard, Interface Standard for Shipboard Systems, Section300A, Electric Power, Alternating Current (Metric)," MIL-STD-1399(Navy) Section 300A, 13 October 1987.

Naval Sea Systems Command, "Shipboard Power Demand Factors, 450 Volt," MS18299 (Ships), Notice 1, 24 July. 1987.

Naval Sea Systems Command, "Report to Congress on Alternative Propulsion Methods for Surface Combatants and Amphibious Warfare Ships," January 2007.

NAVSEA DESIGN PRACTICES and CRITERIA MANUAL, ELECTRICAL SYSTEMS for SURFACE SHIPS, CHAPTER 300, NAVSEA T9300-AFPRO-020.

Navy Statement before the Subcommittee on Projection Forces of the HASC on Integration of Energy Efficient Propulsion Systems For Future U.S. Navy Vessels April 6, 2006.

Neti, Swaroop, " Ship Design Optimization using ASSET ," Master Thesis, Virginia Polytechnic Institute, February 10, 2005.

OPNAVINST 2500.38B " Chapter 3: Navy Tactical Task List (NTTL) ," 30 Jan 2007.

OPNAVINST 9070.1 " Survivability Policy for Surface Ships of the U.S. Navy" dated 23 Sept 1988

OPNAVINST 9072.2 " Shock Hardening of Surface Shisp " dated 12 January 1987

OPNAVINST 9094.1B " Full Power and Economy Trial Requirements for Non-Nuclear Surface Ship Classes " dated 1 August 1996.

O'Rourke, Ronald, " Navy Ship Propulsion Technologies: Options for Reducing Oil Use — Background for Congress ," CRS Report for Congress, RL33360, April 12, 2006.

Partos, D., Conner, D. and Douglass, C. H., "EW & CV FNC Military Utility Assessment: Shipboard Fuel Cells, Fuel Consumption," Center for Naval Analyses, CNA Report CRM D0009169.A1/SR1 of October 2003.

Petry, Chester R., and Jay W. Rumburg, "Zonal Electrical Distribution Systems: An Affordable Architecture for the Future", Naval Engineers Journal, Vol. 105, No. 3, May 1993.

Porche, Isaac, Henry Willis, Martin Ruszkowski, " Framework for Quantifying Uncertainty in Electric Ship Design ,' RAND DB-407-DBR, March 2004.

Qi, Li, “AC System Stability Analysis and Assessment for Shipboard Power Systems,” Ph.D. Dissertation for Texas A&M University, December 2004.

Radan, Damir, " POWER ELECTRONIC CONVERTERS FOR SHIP PROPULSION ELECTRIC MOTORS ," circa 2004

Roberts, David I., “Advanced Electric Technologies for the Fleet”, Statement before the Subcommittee on Research and Development of the House Armed Services Committee Hearing on Navy Transformation, February 20, 2002.

Sauer, Jonathon D., and Paul Thompson, “Electric Propulsion Systems: Past, Present and Future Applications for the Naval and Commercial Market,” presented at the ASNE Electric Machines Technology Symposium, January 27-29, 2004.

Shiffler, Mark E., "Development of a Zonal Architecture Fire Main System for Combatant Ships", Naval Engineers Journal, Vol. 105, No. 3, May 1993, pp. 31-44.

Sudhoff, S.D., Glover, S. F., Zak, S. H., Pekarek, S. D., Zivi, E. J. and Delisle, D. E., “Stability Analysis Methodologies for DC Power Distribution Systems,” presented at the 13th International Ship Control Systems Symposium (SCSS) in Orlando, Florida, 7-9 April 2003.

Surko, S and M. Osborne, “Operating Speed Profiles and the Ship Design Cycle,” Naval Engineers Journal, Summer 2005, pp. 79-85.

Walsh, Edward J., "Naval Systems – Industry Pushing Advanced Technology for Shipboard Power," *USNI PROCEEDINGS*, May 2003, 186.

Webster, James, Howard Fireman, Dillon Allen, Adrian Mackenna, and John Hootman, " US Navy Studies on Alternative Fuel Sources and Power and Propulsion Methods for Surface Combatants and Amphibious Warfare Ships FY2006," Presentation to ASNE DAY 2007.

Yarbrough, Norman R., and Russell E. Kupferer, “The Joint Command and Control Ship (JCC(X)) Approach to Survivability Requirements Development: Total Ship Survivability Assessment,” Association of Scientists and Engineers – 38th Annual Technical Symposium, May 9, 2002.

Zgliczynski, James, Richard Street, James Munro, James McCoy, Neil Hiller, and Jignas Cherry, “The Development and Testing of Integrated Fight-Through Power Modules for the U.S. Navy Fleet,” Electric Machine Technology Symposium (EMTS) 2004, Adam's Mark Hotel, Philadelphia, PA, January 27-29, 2004.

APPENDICES

(This Page Left Intentionally Blank)

Appendix A Quality of Service and Zonal Survivability

A.1 Surface Ship Survivability: Zonal Survivability

Design Threat

A design threat is a threat to the ship where a Design Threat Outcome has been defined. Examples of Design Threats could be specific cruise missiles, torpedoes, guns, explosives, weapons of mass destruction as well as accidents such as main space fires, helicopter crashes, collisions, and groundings.

Design Threat Outcome

The design threat outcome is the acceptable performance of the ship in terms of the aggregate of susceptibility, vulnerability, and recoverability when exposed to a design threat. Possible Design Threat Outcomes include:

- a. Ship will likely be lost with the loss of over 25% of embarked personnel.
- b. Ship will likely be lost with the loss of 25% or under of embarked personnel.
- c. Ship will likely remain afloat and not be capable of performing one or more primary mission areas for a period of time exceeding one day.
- d. Ship will likely remain afloat and be capable of performing all of its primary mission areas following restoration efforts not exceeding one day using only that external assistance that is likely available within the projected operating environment.
- e. Ship will likely remain afloat and be capable of performing all of its primary mission areas following restoration efforts not exceeding two hours using only organic assets.
- f. Ship will likely remain afloat and would be capable of performing all of its primary mission areas following restoration efforts (if needed) not exceeding 2 minutes using only organic assets.
- g. Ship will likely remain afloat and would likely be capable of performing all of its primary mission areas without interruption.
- h. The threat weapon is not considered a significant threat because the probability that the threat weapon would have been defeated before striking the ship is greater than 98%.

Note: The term “likely” should be assigned a specific probability of occurrence. A reasonable choice would be to specify that “likely” refers to a probability of occurrence greater than 86%.

Over-Matching Threat

An over-matching threat is a design threat where the design threat outcome includes likely loss of the ship.

Zone

A zone is a geographic region of ship. In a general sense, the boundaries of the zone can be arbitrary, but to maximize survivability, the zones of multiple distributed systems as well as damage control zones should be aligned. For shipboard distributed systems, this typically means the zone boundaries are the exterior skin of the ship and selected transverse watertight bulkheads. The zone boundaries may rise above the watertight bulkheads into the superstructure, or the superstructure may be composed of one or more zones independent of the zones within the hull.

Adjacent Zones

Adjacent Zones are zones that could simultaneously be damaged by a design threat. Zones are typically sized so that usually only 2 zones are simultaneously damaged by a design threat, although in some cases a third zone (such as the superstructure) may also be damaged.

Zonal Survivability

For a distributed system, zonal survivability is the ability of the distributed system, when experiencing internal faults due to damage or equipment failure confined to adjacent zones, to ensure loads in undamaged zones do not experience a service interruption. Zonal Survivability assures damage does not propagate outside the adjacent zones in which damage is experienced. For many distributed system designs, zonal survivability requires that at least one longitudinal bus remains serviceable, even through damaged zones.

At the ship level, zonal survivability facilitates the ship, when experiencing internal faults in adjacent zones due to design threats, to maintain or restore the ships primary missions as required by the Design Threat Outcome. Ship level zonal survivability focuses restoration efforts on the damaged zones, simplifying the efforts required of the ship's crew to maintain situational awareness and take appropriate restorative actions. Ship level zonal survivability requires sufficient damage control features to prevent the spreading of damage, via fire or flooding, to zones that were not initially damaged.

Compartment Survivability

Zonal Survivability only addresses loads outside of the damaged adjacent zones. For some important loads, including those implementing mission systems, providing redundant capability across multiple non-adjacent zones may prove to be infeasible. This situation often arises in the superstructure where the sensor masts are located in the same or adjacent zones. In some cases, these loads may be perfectly functional although damage has reached into its zone. Likewise, maximizing the probability of maintaining emergency loads that support damage control efforts within the damaged adjacent zones also assists in preventing the spread of damage to zones not initially impacted. Examples of such loads include emergency lighting and power receptacles for

portable dewatering pumps. In these cases, providing Compartment Survivability for the distributed systems for the specific loads is warranted. Compartment Survivability requires that every distributed system required by a specific load provide independent normal and alternate sources of its commodity (power, cooling water, etc.).

For the specific design threat, one of the sources of the commodity should be expected to survive if the specific load is expected to survive. The point at which the in zone distribution of the commodity merge (such as with an Automatic Bus Transfer – ABT) from the normal and alternate sources should be located “close” to the specific load.

A.2 Submarine Survivability

Submarine Survivability is different from surface ship survivability. In general, submarine survivability is concerned with shock events. Of importance is the ability of individual electrical components and assemblies to survive when the ship experiences a shock event, and the ability of the power system to maintain or restore service following the simultaneous transient misoperation or complete failure of multiple electrical components across the entire submarine.

A.3 Quality of Service

QOS is a metric of how reliable a distributed system provides its commodity to the standards required by the users. It is calculated as a Mean-Time-Between-Service-Interruption (MTBSI) as viewed from the loads. A failure is defined as any interruption in service, or commodity parameters outside of normal parameters, that results in a mission system not being capable of fulfilling mission requirements. The time is usually measured over an operating cycle or Design Reference Mission. QOS is a reliability metric, as such the calculation of QOS metrics does not take into account survivability events such as battle damage, collisions, fires, or flooding. Quality of Service does take into account equipment failures and normal system operation transients. A typical cause of normal system operation causing a QOS failure is shifting to/from shore power (without first paralleling) or manually changing the source of power using a Manual Bus Transfer (MBT). Also note that not all interruptions in service will cause a QOS failure. Some loads, such as refrigerators and chill boxes, will keep their contents cold even if power is interrupted for several minutes. In this case, a QOS failure will not occur as long as power is restored in time to prevent significant heating of the contents. Note that the optimal configuration of a distributed system may be different for QOS considerations and for survivability considerations. In the electric plant for example, the most important QOS consideration is the ability to preserve power to loads when a generation element trips off line while damage to the distribution system and the ability to preserve power to vital mission systems loads is of major interest in the survivability analysis. For QOS reasons, many ships operate with their electric plant paralleled in peacetime steaming and only shift to the more survivable split plant configuration under threat conditions.

For electrical power systems, loads can be categorized into four QOS categories: Uninterruptible, Short Term Interrupt, Long Term Interrupt, and Exempt Loads.

a. Un-interruptible Load

Un-interruptible Load is a QOS term for categorizing electrical loads that can not tolerate power interruptions of 2 seconds. Un-interruptible Loads should be capable of tolerating transient interruptions of power of up to 10 milliseconds in duration to enable standby power systems to switch. Un-interruptible loads are typically provided a Standby Power System, an Uninterruptible Power Supply, or auctioneering DC diodes.

b. Short Term Interrupt Load

An electrical load is classified as a Short Term Interrupt Load if it can tolerate power interruptions greater than 2 seconds but can not tolerate interruptions of 5 minutes or more. 2 seconds is based on providing sufficient time for electromechanical switchgear to clear faults in a coordinated manner, conduct Quality of Service Load Shedding of Long Term Interrupt Loads, and to reconfigure the electrical plant. 5 minutes is a nominal time in which a standby generator should be capable of starting and providing power.

c. Long Term Interrupt Load

An electrical load is classified as a Long Term Interrupt Load if it can tolerate power interruptions greater than 5 minutes. Examples include resistive heaters, chill and freeze boxes, and standby redundant equipment.

d. Exempt Loads

For IPS configurations where propulsion and ship service power are provided by the same set of power generation modules / prime movers, sufficient redundancy in generation is not generally provided to enable the ship to achieve its maximum speed with any one generator out of service. The installed generation capacity of the ship must be capable of supporting the ship service load and all categories of propulsion load with all generators online, and must support the ship service load and all but the Exempt Load with one generator out of service. Unless otherwise specified in the ship's requirements documentation, that portion of propulsion load needed to exceed the minimum tactical speed should be designated exempt.

The concept of the Exempt Load is only used in sizing the installed generation capacity of the ship. In operation of the power system, exempt load are treated as long-term interrupt loads.

Appendix B NGIPS Functional Architecture

The Integrated Power Architecture (IPA) provides the framework for partitioning the equipment and software of IPS (and NGIPS) into modules. IPA defines six functional elements and the power, control and information relationships between them. Every IPS module corresponds to one of the IPA functional elements. A power relationship is one involving the transfer of electrical power between two functional elements. A control relationship refers to the transmission of commands from one functional element to another while an information relationship refer to the transmission of data from one functional element to another. The six functional elements are Power Generation, Power Distribution, Power Conversion, Power Load, Energy Storage and System Control.

B.1 Power Generation:

A Power Generation Functional Element converts fuel into electrical power. The electrical power is transferred to one or more Power Distribution Functional Elements. A Power Generation Functional Element exchanges control and information signals only with System Control Functional Elements. An associated Power Generation Module might typically consist of either a gas turbine or diesel engine, a generator, a rectifier, auxiliary support submodules and module controls. Other possible technologies include solar cells, fuel cells, or other direct energy conversion concepts.

B.2 Power Distribution:

A Power Distribution Functional Element transfers electrical power between other Functional Elements. Whenever possible, control and information signals should only be exchanged with System Control Functional Elements. Power Distribution elements should only communicate directly with other functional elements (other than System Control) only in limited cases where latency and network speed of the Machinery Control System is not sufficient for system protection. Fault protection systems should be designed, if possible, to not require the power distribution modules to communicate control signals with any functional element other than system control. An associated Power Distribution Module might typically consist of bus duct, cables, switchgear and fault protection equipment.

B.3 Power Conversion:

A Power Conversion Functional Element converts electrical power from the form of one Power Distribution Functional Element to the form of another Power Distribution Functional Element. Power may be transferred only to and from Power Distribution Functional Elements. Control and Information signals can be exchanged only with System Control Functional Elements. An associated Power Conversion Module would typically consist of a solid state power converter. Another possibility is a transformer. The power conversion equipment associated with generators and motors are, however, part of the Power Generation and Power Load Functional Elements respectively. They are not considered part of a Power Conversion Functional Element.

B.4 Power Load:

A Power Load Functional Element is a user of electrical power received from one or more Power Distribution Functional Elements. A Power Load may optionally deliver power to one or more Power Distribution Functional Elements under transient conditions (regenerative braking for example). A Power Load may exchange control and information signals with System Control Functional Elements, external (non-IPS) systems, and in limited cases Power Distribution Functional Elements (See Power Distribution). Associated Power Load Modules include Propulsion Motors and ship service loads.

B.5 Energy Storage:

An Energy Storage Functional Element stores energy. Power is transmitted to and from one or more Power Distribution Functional Elements via electric power. An Energy Storage Functional Element exchanges control and information signals with only System Control Functional Elements.

B.6 System Control:

A System Control Functional Element consists of the software necessary to coordinate multiple other Functional Elements. A System Control Functional Element receives information from other functional elements and possibly external (non-IPS) systems. Similarly, a System Control Functional Element may receive control commands from or negotiate control actions with external systems and other functional elements. A System Control Functional Element resides on an external distributed computer system and therefore does not have a power interface.

Appendix C Power Density and Ship Size

The NGIPS technical architecture proposes two different power generation architectures based on whether a ship design would benefit from high power density or not. A general observation is that larger ships have a less need for power dense machinery than smaller ships. As can be seen by the historical example in Figure 20, the amount of power required to move a ton of ship at a given speed decreases as ship displacement becomes larger. Conversely, as the ship becomes smaller, the machinery must either become more power dense, or consume an increasing percentage of the full load displacement.

- Three ships: Close in speed, same technology, same design organization
- *Sumner* class DD (36 knots)
 - 60,000 SHP/3,218 tons
 - = 18.6 hp/ton
- *Cleveland* class CL (33 knots)
 - 100,000 SHP/14,131 tons
 - = 7.1 hp/ton
- *Iowa* class BB (33 knots)
 - 212,000 SHP/57,540 tons
 - = 3.7 hp/ton

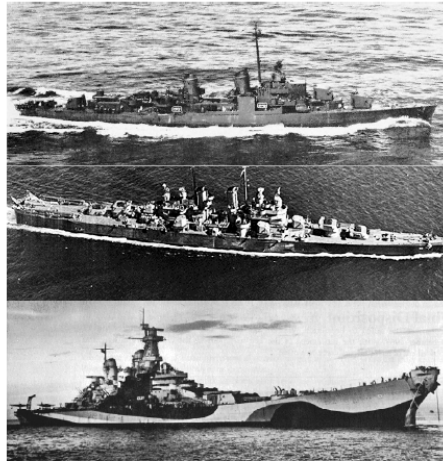

Figure 20: Machinery Economy of Scale

An explanation for why this economy of scale exists lies in the physics of ship drag. The drag of a ship is usually expressed in terms of drag coefficients:

$$R = \frac{1}{2} \rho S V^2 (C_F + C_R)$$

Where:

- R is the ship's resistance or drag
- ρ is the density of saltwater
- S is the wetted surface area
- V is the ship's speed
- C_F is the Frictional Drag Coefficient
- C_R is the Residual Drag Coefficient

The first observation to note is that the volume (and displacement) of a ship increases as the cube of the length, while the wetted surface area increases as the square of the length. If we assumed that the Frictional and Residual Drag Coefficients remained constant as the length varied, then if we doubled the dimensions of a ship, the volume would increase by a factor of 8, but the resistance (and power, assuming a constant propulsive coefficient) needed to achieve a given speed would only increase by a factor of 4. In reality, for displacement ships, the Frictional Drag coefficient decreases slightly with increasing length. The Residual Drag Coefficient may locally increase or decrease with increasing ship length with the general trend of decreasing with increased length. The net result is that for most displacement vessels, doubling the dimensions would result in resistance (and power) increasing by a factor of about 4 while the volume (and displacement) increased by a factor of 8. If the density of the propulsion equipment was held constant, than the percentage of full load displacement allocated to propulsion would be inversely proportional to length. In reality, the density of the propulsion equipment is a function of the equipment selected. Figure 21 shows the propulsion equipment (Group 2) weight fraction of full load displacement results of a set of scaled ASSET ship concepts as compared to the idealized inverse relationship. Note that the inverse relationship holds well for longer ships, and that for shorter ship lengths, the percentage of full load displacement used by propulsion equipment is greater than predicted by the inverse law – likely due to increased power density of propulsion equipment of higher power ratings.

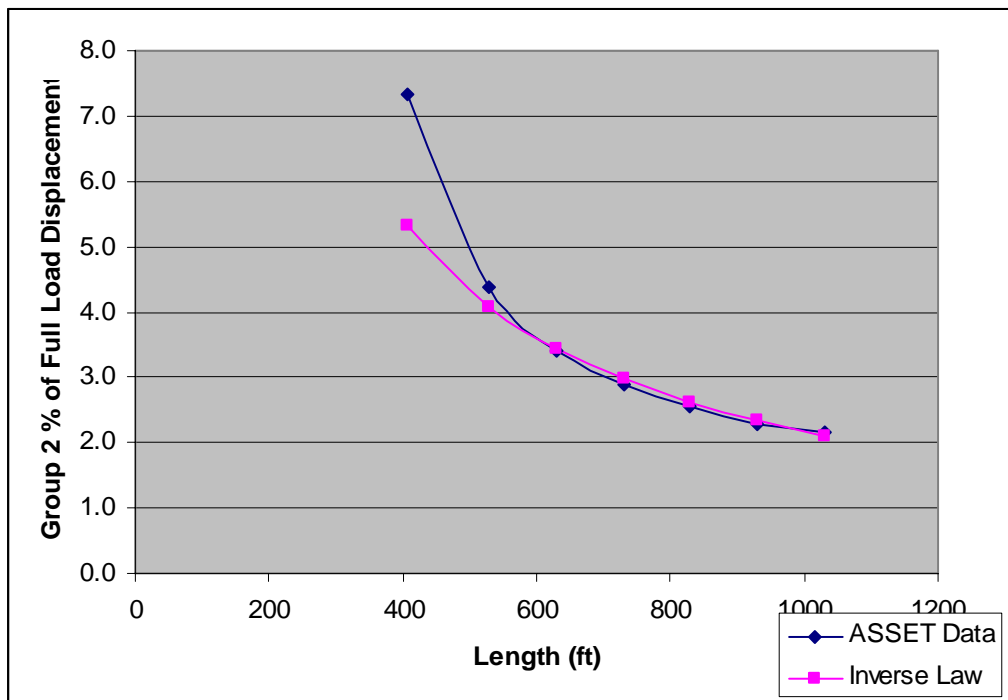

Figure 21: Group 2 Percentage of Full Load Displacement vs ship Length

If instead, we were to hold the percentage of full load displacement allocated to propulsion power a constant, then the power density (MW/ton) required of the propulsion equipment would be roughly inversely proportional to the length. Smaller ships would need more power dense propulsion equipment than larger ships.

Figure 22 provides another view from the set of scaled ASSET ship concepts. For a small ship, the payload (mission systems) comprises only 10% of the full load displacement while for large ships, the payload comprises about 45% of the full load displacement. In other words, to add a ton of mission system to a small ship requires an additional 9 tons of ship, while adding a ton of mission system to a large ship only requires an additional 1.2 tons of ship. If we traded away a ton of propulsion plant for a ton of mission system by improving the power density, then the ship could theoretically avoid the additional 9 tons of ship that the additional ton of mission systems would otherwise require. As long as the cost of improved power density is less than the 9 tons of avoided additional ship, then the improved power density propulsion system will result in the greater value. Conversely, increased power density is harder to justify for larger ships where an additional ton of mission system has a much smaller impact on the ship.

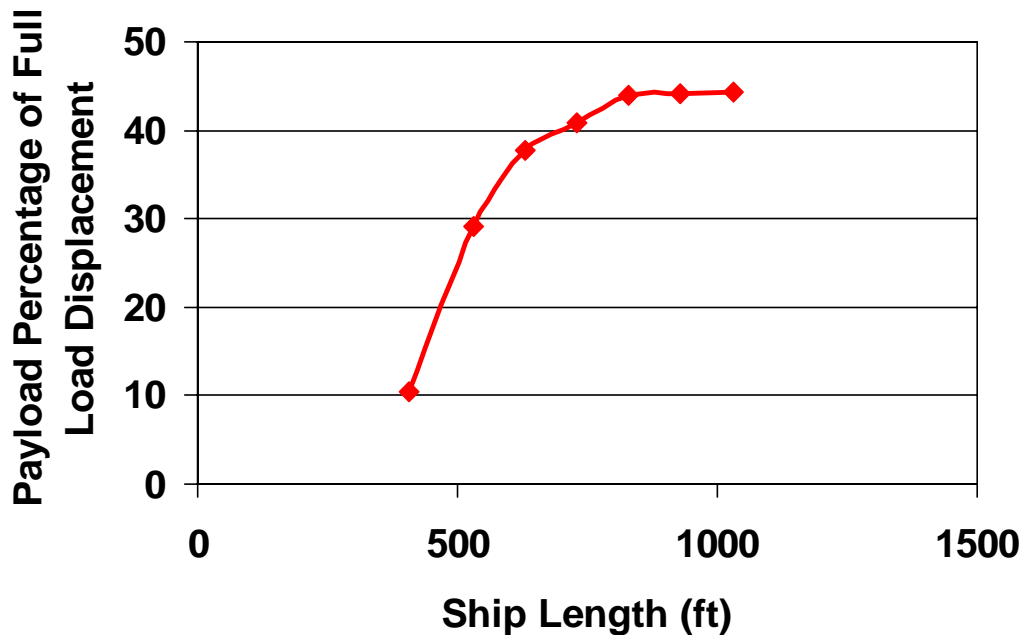

Figure 22: Payload Percentage of Full Load Displacement vs Ship length

As confirmed by Figure 23, the initial steep part of the Payload Percentage vs Ship Length curve of Figure 22 corresponds to scaled ASSET ship concept full load displacements below 10,000 lton. Likewise, the flat part of the curve corresponds to scaled ASSET ship concept full load displacements above 25,000 lton.

In conclusion, the basic physics of ship scaling indicates that power density has greater value for smaller ships. For larger ships, affordability considerations will generally result in less power dense propulsion solutions.

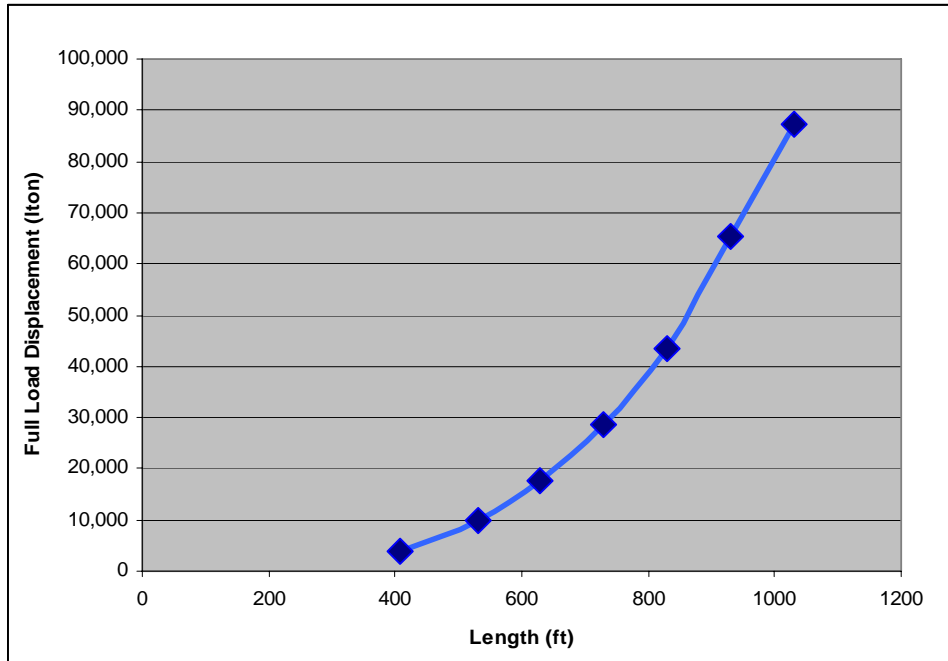

Figure 23: Full Load Displacement vs Length for scaled ASSET ship concepts

Appendix D Industry Trends

There is an expressed interest in knowing how industry outside of the Navy views current and future power technology. The interest here is for the Navy to leverage commercial power technology to the maximum possible extent. To assess the issue, a panel of technical experts from the Navy, Office of Naval Research, and academia met at the US Naval Academy on 9 October, 2007 to discuss their views. The panel members are:

- CAPT Norbert Doerry, Ph.D.
- Dr. John Amy
- Dr. Scott Sudhoff
- Dr. Ed Zivi
- Dr. John Ciezki
- Dr. Robert Hebner
- Terry Ericson

For the purpose of this panel discussion, an assumption is made that NGIPS technology will be introduced into the fleet over the time period of 10 years (near term) to 30 years (far term) from now. Once introduced into the fleet, NGIPS technology would then be in service for 30 to 50 years. The panel was then tasked to forecast how the industrial base will evolve over the next several decades. Relative to a DDG-1000 baseline, some of the key objectives for NGIPS are:

- Increased technology readiness levels
- Increased power density
- Decreased system cost / life cycle cost
- Improved power quality / reliability / survivability / continuity of service
- Improved EMC / EMI / grounding / protection / safety
- Improved support for large, pulse loads
- Reduced signature for improved “Stealth”
- “Open Architecture” with reduced system integration risk
- Multi-vendor industrial base

- Increased operational flexibility
- Incorporation of emerging control and automation technologies

The panelists agreed that while some sectors in commercial industry are seeking efficient power generation and distribution systems for large load requirements, potential solutions are not constrained by size and weight. Conversely, other industry sectors that are spatially limited do not require supplying comparatively large loads. The Navy is unique – both inside and outside the Department of Defense – in that many of its ships require very high power density. That is, high power solutions (including high-energy pulse power applications) within a small footprint. In spite of the Navy’s distinct challenges, certain industry sectors may provide some overlap with the NGIPS technology roadmap. The following questions bear this out:

Question 1: Compared to the Navy, what industry sectors (foreign or domestic) have similar power system requirements?

The transportation industry shares a common interest in higher power density applications because of their moderate power needs and relatively small volume. Conveyances such as hybrid and all-electric automobiles, high speed passenger trains, jet airliners, unmanned autonomous vehicles, and even all-electric lighter than air aircraft are potential applications for power dense technology. Although the transportation industry seeks power dense solutions, these applications do not have to supply high power loads. A Boeing 787, for example, may distribute approximately 1 MW of power. By comparison, NGIPS must supply 1 to 2 orders of magnitude higher than that. High-speed turbines rated up to a few kV DC may be used in high speed passenger train applications, where Europe and Japan hold a niche market.

While the transportation industry may have similar power density challenges, it should be noted that the Navy needs to design systems that are an order of magnitude higher in terms of reliability. For example, an average passenger car in the US is designed to last between 3000-4000 hours, which is less than 6 months of continuous operation; one 6-month deployment alone on a Navy warship can exceed the life expectancy of a commercial vehicle. The Navy needs to design reliable systems comprised of unreliable components; specifically, we need to understand the failure modes within our semiconductors and design the power electronics so that they last the life of the ship.

Although not likely to go to MVDC systems, the utility industry has high-power power electronics, flexible ac transmission systems, renewables, energy storage, and distributed generation. But even in downtown Tokyo they don’t have the power density issues that the Navy does. For diverse power generation applications, this industry also researches alternate forms of multi-frequency power generation such as nuclear, wind, solar, and wave. For this application, the power must eventually be converted to the standard 50 and 60 Hz AC, which has potential for leveraging power conversion technology; it may also drive down the cost of some power conversion components.

Question 2: What industry sectors (foreign or domestic) are interested in higher frequency AC (240 – 300 Hz) AC distribution systems or medium voltage (6.9kV – 13.8 kV) DC distribution systems?

The panel was unanimous that no other industry sector (foreign or domestic) is known to be pursuing higher frequency (240 – 300 Hz) AC distribution systems.

There are several industry sectors interested in medium voltage (6.9kV – 13.8kV) DC applications. Among those are steel mills, mines, processing plants, and marine applications. Several industry sectors have chosen MVDC power to realize a reduction in the size of the cables. Whether the cable is run from the top of the on-pylon windmills to the ground station, through the mining shaft to the work station, or down to the pumping station on the ocean floor, higher voltage distribution systems mean lower current and a reduction in cable size and weight.

For similar reasons as the Navy, state-of-the-art DC distribution in motor drives for marine applications are also being used, although this industry does not have to contend with the survivability standards and power requirements unique to the Navy. Others, such as the commercial aircraft industry, may be pursuing DC distribution, but they are relatively low voltage systems. DC distribution systems for process control industries and steel mining, for example, are on the order of hundreds of volts to a few kV. It is doubtful that they are going to go any higher than that over the next 10-30 years.

Question 3: What opportunities are there to leverage improvements in industrial technology over the next 10-30 years?

- a. Distributed Generation - Potential technology leveraging from on-pylon in wind farms.
- b. Power electronics – Silicon Carbide-based power electronics, which can get closer to the voltage levels the Navy needs. Current capacity (cable size and weight) will decrease as the technology matures.
- c. Electric vehicle – Big potential market. Drive-by-wire control.
- d. COTS processors – Common electric interface for COTS processors between USA, Europe and Asia – there's a market there.
- e. Energy production – Motor drives and pumping stations on the deep sea floor are powered by cables run from the surface. There is incentive to reduce the cable size through MVDC power distribution.
- f. Solid state power substations (SSPS). Solid state transformers are smaller and lighter, which is a desirable quality on utility poles. Especially with distributed generation.

Question 4: Where is the commercial maritime electric drive sector going?

Power requirements on next generation warships are projected to exponentially increase. By comparison, commercial ship loads saw a large increase in power requirements as everything became electrified. Now, through improvements to the power distribution architectures the net load on commercial ships have started to stabilize and even decrease slightly as extra conversion steps are eliminated. Ship service loads on NGIPS warships are expected to level off, but power requirements for high powered weapons, solid state phased array radars, and other mission systems are expected to increase in the foreseeable future.

Question 5: Where is the industrial sector going with respect to control and automation?

Control and automation architectures for power distribution systems are still at an early stage. The all electric warship can be viewed as a dynamically interdependent system of systems, and it is quite challenging to develop a control and automation architecture capable of achieving the desired behavior in terms of stability and performance. What's more, Naval all-electric warships are unique with their life critical, non-stop nature under disruptive battle conditions. However, technology overlaps in control and automation as many commercial sectors are dependent on the similar quality of service issues as the Navy. Take for instance the process industry's dependence on nonstop operations where millions of dollars can be lost from a loss of power quality.

By and large, much of industry still has focused more on local automation, remote monitoring and remote control. Integrated control technology in industry is not well-advanced but is moving towards more sophisticated control architectures. For example, the land-based power industry is trying to retrofit its power grid with a "smart grid" - a system control architecture designed to sense faults and reconfigure, protect, or optimize as necessary. Also, the state-of-the-art agile process industry has developed both responsive and flexible automation, which reacts to changing requirements very rapidly.

Appendix E NGIPS Technology Development Roadmap Details

E.1 Medium Voltage AC Power (MVAC)

- MVAC-1: Develop and/or update standards, design data sheets, design tools, and design data to provide consistency in design across ship classes.
- MVAC-1-1: Develop Design Data Sheet for sizing Power Generation Modules for MVAC applications
(Prerequisite: none)
 - MVAC-1-2: Develop Design Data Sheet for Endurance Fuel Calculations for MVAC applications (Prerequisite: none)
 - MVAC-1-3: Develop Mobility System Design and Integration Handbook for MVAC applications (Prerequisite: none)
 - MVAC-1-4: Develop MVAC Power Generation System Design and Integration Handbook (Prerequisite: none)
 - MVAC-1-5: Update ASSET to incorporate Design Data Sheets and Design Handbooks (Prerequisite: MVAC-A1-1,2,3,4)
 - MVAC-1-6: Develop and maintain Module Characterization Sheets for MVAC modules. (Prerequisite: none for existing, module developments for new modules)
 - MVAC-1-7: Update Naval Vessel Rules
(Prerequisite: MVAC-1-1,2,3,4)
 - MVAC-1-8: Update GENSPECS for Overhauls
(Prerequisite: MVAC-1-1,2,3,4)
 - MVAC-1-9: Develop Performance Specification for Diesel based PGM interfacing to MVAC (Prerequisite: MVAC-1-1,2,3,4)
 - MVAC-1-10: Develop Performance Specification for Gas Turbine based PGM interfacing to MVAC (Prerequisite: MVAC-1-1,2,3,4)
 - MVAC-1-11: Develop Performance Specification for in-hull propulsion motor modules interfacing to MVAC
(Prerequisite: MVAC-1-1,2,3,4)

MVAC-1-12: Develop Performance Specification for MVAC Power Distribution Modules (Prerequisite: MVAC-1-1,2,3,4)

MVAC-1-13: Develop a Software Requirements Document for the PCON Module required to support MVAC. (Prerequisite: MVAC-1-1,2,3,4)

MVAC-1-14: Develop Performance Specification for MVAC Power Transformers. (Prerequisite: MVAC-1-1,2,3,4)

E.2 High Frequency AC Power (HFAC)

HFAC-1: Develop and/or update standards, design data sheets, design tools, and design data. to provide consistency in design across ship classes.

HFAC-1-1: Update Design Data Sheet for sizing Power Generation Modules to include HFAC applications (Prerequisite: none)

HFAC-1-2: Update Design Data Sheet for Endurance Fuel Calculations to include HFAC applications (Prerequisite: none)

HFAC-1-3: Update Mobility System Design and Integration Handbook to include HFAC applications (Prerequisite: none)

HFAC-1-4: Develop HFAC Power Generation System Design and Integration Handbook. Include methods for addressing increased ground fault currents. If necessary, conduct a study to determine the maximum ground fault current that should be allowed. (Prerequisite: HFAC-B2,B3,B4,B5,B6,B8,B14)

HFAC-1-5: Update ASSET to incorporate Design Data Sheets and Design Handbooks (Prerequisite: HFAC-1-1,2,3,4)

HFAC-1-6: Develop and maintain Module Characterization Sheets for HFAC modules. (Prerequisite: Design of Modules)

HFAC-1-7: Update Naval Vessel Rules (Prerequisite: HFAC-1-1,2,3,4)

HFAC-1-8: Update GENSPECS for Overhauls (Prerequisite: HFAC-1-1,2,3,4)

HFAC-1-9: Update Performance Specification for Diesel based PGM to include interfacing to HFAC (Prerequisite: HFAC-1-1,2,3,4)

- HFAC-1-10: Update Performance Specification for Gas Turbine based PGM to include interfacing to HFAC
(Prerequisite: HFAC-1-1,2,3,4)
- HFAC-1-11: Update Performance Specification for in-hull propulsion motor modules to include interfacing to HFAC
(Prerequisite: HFAC-1-1,2,3,4)
- HFAC-1-12: Develop Performance Specification for HFAC Power Distribution Modules
(Prerequisite: HFAC-1-1,2,3,4)
- HFAC-1-13: Update Software Requirements Document for the PCON Module to include requirements to support HFAC.
(Prerequisite: HFAC-1-1,2,3,4)
- HFAC-1-14: Develop Performance Specification for HFAC Power Transformers.
(Prerequisite: HFAC-1-1,2,3,4)

Deadline A:

None

Deadline B:

- HFAC-B1: Establish an equipment qualification facility and associated processes/methods.
 - HFAC-B1-1: Conduct a study to determine different methods to implement an equipment qualification facility and associated processes/methods. Scope the effort needed to implement each of the methods. Determine the cost effectiveness of each method.
(Prerequisite: None)
 - HFAC-B1-2: Establish an HFAC equipment qualification facility.
(Prerequisite: HFAC-B1-1)
 - HFAC-B1-3: Develop written qualification processes and methods for HFAC equipment.
(Prerequisite: HFAC-B1-1)
- HFAC-B2: Develop and demonstrate HFAC system stability and bus overvoltage stability standard. Document in a design standard.
 - HFAC-B2-1: Conduct a study to determine different methods to ensure HFAC system stability and bus overvoltage stability. Perform Concept

Designs of candidate methods and perform dynamic simulations to verify effectiveness.

(Prerequisite: None)

HFAC-B2-2: Conduct a design space study to determine which of the effective methods identified in HFAC-B2-1 are most cost effective when integrated into ship systems.

(Prerequisite: HFAC-B2-1)

HFAC-B2-3: Design, Build, and Test one or more Advanced Development Model(s) demonstrating the cost effective solutions identified in HFAC-B2-2.

(Prerequisite: HFAC-B2-2)

HFAC-B2-4: Develop a HFAC System Stability and bus overvoltage stability Design Data Sheet for HFAC.

(Prerequisite: HFAC-B2-3)

HFAC-B3: Demonstrate and test a Full Scale demonstration of an HFAC system.
(As Required to support Acquisition)

Deadline C:

None

E.3 Medium Voltage DC Power (MVDC)

MVDC-1: Develop and/or update standards, design data sheets, design tools, and design data. to provide consistency in design across ship classes.

MVDC-1-1: Develop Design Data Sheet for sizing Power Generation Modules for MVDC applications

(Prerequisite: none)

MVDC-1-2: Update Design Data Sheet for Endurance Fuel Calculations for MVDC applications (Prerequisite: none)

MVDC-1-3: Update Mobility System Design and Integration Handbook for MVDC applications (Prerequisite: MVDC-C5-2)

MVDC-1-4: Develop MVDC Power Generation System Design and Integration Handbook (Prerequisite: MVDC-C5-2)

MVDC-1-5: Update ASSET to incorporate Design Data Sheets and Design Handbooks (Prerequisite: MVDC-1-1,2,3,4)

- MVDC-1-6: Develop and maintain Module Characterization Sheets for MVDC modules. (As required)
- MVDC-1-7: Update Naval Vessel Rules (Prerequisite: MVDC-1-1,2,3,4, MVDC-C2-4)
- MVDC-1-8: Update GENSPECS for Overhauls (Prerequisite: MVDC-1-1,2,3,4)
- MVDC-1-9: Develop Performance Specification for Diesel based PGM interfacing to MVDC (Prerequisite: MVDC-1-1,2,3,4)
- MVDC-1-10: Develop Performance Specification for Gas Turbine based PGM interfacing to MVDC (Prerequisite: MVDC-1-1,2,3,4)
- MVDC-1-11: Develop Performance Specification for in-hull propulsion motor modules interfacing to MVDC (Prerequisite: MVDC-1-1,2,3,4)
- MVDC-1-12: Develop Performance Specification for MVDC Power Distribution Modules (Prerequisite: MVDC-1-1,2,3,4)
- MVDC-1-13: Develop a Software Requirements Document for the PCON Module required to support MVDC. (Prerequisite: MVDC-1-1,2,3,4,)

Deadline A:

None

Deadline B:

None

Deadline C:

MVDC-C1: Develop and demonstrate System Fault Detection and Isolation methods. Document in a design standard.

- MVDC-C1-1: Conduct a study to determine different methods to implement a Fault Detection and Isolation system on MVDC. Perform Concept Designs of candidate methods and perform dynamic simulations to verify effectiveness. (Prerequisite: None)

MVDC-C1-2: Conduct a design space study to determine which of the effective methods identified in MVDC-C1-1 are most cost effective when integrated into ship systems.

(Prerequisite: MVDC-C1-1)

MVDC-C1-3: Design, Build, and Test one or more Advanced Development Model(s) demonstrating the cost effective solutions identified in MVDC-C2-2.

(Prerequisite: MVDC-C1-2)

MVDC-C1-4: Develop a MVDC Fault Detection and Isolation Design Data Sheet.

(Prerequisite: MVDC-C1-3)

MVDC-C2: Develop and demonstrate MVDC system stability and bus overvoltage stability standard. Document in a design standard.

MVDC-C2-1: Conduct a study to determine different methods to ensure MVDC system stability and bus overvoltage stability. Perform Concept Designs of candidate methods and perform dynamic simulations to verify effectiveness.

(Prerequisite: None)

MVDC-C2-2: Conduct a design space study to determine which of the effective methods identified in MVDC-C2-1 are most cost effective when integrated into ship systems.

(Prerequisite: MVDC-C2-1)

MVDC-C2-3: Design, Build, and Test one or more Advanced Development Model(s) demonstrating the cost effective solutions identified in MVDC-C2-2.

(Prerequisite: MVDC-C2-2)

MVDC-C2-4: Develop a MVDC System Stability and bus overvoltage stability Design Data Sheet for MVDC.

(Prerequisite: MVDC-C2-3)

MVDC-C3: Develop and demonstrate a system grounding and galvanic isolation method. Document in a design standard.

MVDC-C3-1: Conduct a study to determine different methods to perform system grounding and galvanic isolation of MVDC systems. Perform Concept Designs of candidate methods and perform dynamic simulations to verify effectiveness.

(Prerequisite: None)

MVDC-C3-2: Conduct a design space study to determine which of the effective methods identified in MVDC-C3-1 are most cost effective when integrated into ship systems.

(Prerequisite: MVDC-C3-1)

MVDC-C3-3: Design, Build, and Test one or more Advanced Development Model(s) demonstrating the cost effective solutions identified in MVDC-C3-2.

(Prerequisite: MVDC-C3-2)

MVDC-C3-4: Develop a MVDC System Grounding and Galvanic Isolation Design Data Sheet for MVDC.

(Prerequisite: MVDC-C3-3)

MVDC-C4: Develop an MVDC Test Infrastructure

MVDC-C4-1: Conduct a study to determine different methods to implement an equipment qualification facility and associated processes/methods. Scope the effort needed to implement each of the methods. Determine the cost effectiveness of each method.

(Prerequisite: None)

MVDC-C4-2: Establish an MVDC equipment qualification facility.

(Prerequisite: MVDC-C4-1)

MVDC-C4-3: Develop written qualification processes and methods for MVDC equipment.

(Prerequisite: MVDC-C4-1)

MVDC-C5: Develop MVDC System Integration Methods. Document in a design standard.

MVDC-C5-1: Conduct a study to determine different methods to integrate MVDC systems. Perform Concept Designs of candidate methods and perform dynamic simulations to verify effectiveness.

(Prerequisite: None)

MVDC-C5-2: Conduct a design space study to determine which of the effective methods identified in MVDC-C5-1 are most cost effective when integrated into ship systems. Select method for incorporation into Mobility System Design and Integration Handbook for MVDC applications (MVDC-1-3)
(Prerequisite: MVDC-C5-1)

MVDC-C6: Demonstrate and test a Full Scale demonstration of an MVDC system.
(As Required to support Acquisition)

E.4 Zonal Electrical Distribution Systems (ZEDS)

ZEDS -1: Develop and/or update standards, design data sheets, design tools, and design data. to provide consistency in design across ship classes.

ZEDS 1-1: Develop Zonal Electrical Distribution System Design and Integration Handbook
(Prerequisite: ZEDS –A1,A2,A4)

ZEDS -1-2: Update ASSET to incorporate ZEDS Design and Integration Handbook
(Prerequisite: ZEDS -1-1)

ZEDS -1-3: Develop and maintain Module Characterization Sheets for ZEDS modules.
(As required)

ZEDS -1-4: Update Naval Vessel Rules
(Prerequisite: ZEDS -1-1)

ZEDS -1-5: Update GENSPECS for Overhauls
(Prerequisite: ZEDS -1-1)

ZEDS -1-6: Develop Performance Specification for ZEDS Power Distribution Modules
(Prerequisite: ZEDS -1-1)

ZEDS -1-7: Develop a Software Requirements Document for the PCON Module required to support ZEDS.
(Prerequisite: ZEDS -1-1)

Deadline A:

ZEDS –A1: Develop and document a method for amalgamating loads for sizing distribution system equipment.

ZEDS –A1-1: Conduct a study to determine different methods to amalgamate loads to size distribution system equipment. Exercise different methods on representative ship concepts and perform analysis to determine method effectiveness.

(Prerequisite: ZEDS -A2-1)

ZEDS -A2: Develop and document a method for estimating loads by QOS category and survivability category.

ZEDS –A2-1: Conduct a study to determine different methods to estimate loads by QOS categories. Exercise different methods on representative ship concepts and perform analysis to determine method effectiveness.

(Prerequisite: None)

ZEDS -A3: Develop and document a control system interface standard for NGIPS to communicate with loads to enable flexible load shed and load management strategies. Interface standard should include physical, electrical, and logical interfaces.

ZEDS –A3-1: Conduct a study to determine different methods to implement a communications interface between loads and ZEDS. Perform Concept Designs of candidate methods and perform dynamic simulations to verify effectiveness.

(Prerequisite: none)

ZEDS -A3-2: Conduct a design space study to determine which of the effective methods identified in ZEDS-A3-1 are most cost effective when integrated into ship systems.

(Prerequisite: ZEDS –A3-1)

ZEDS –A3-3: Design, Build, and Test one or more Advanced Development Model(s) demonstrating the cost effective solutions identified in ZEDS -A3-2.

(Prerequisite: ZEDS –A3-2)

ZEDS-A3-4: Develop a standard defining the interface to communicate with loads to enable flexible load shed and load management strategies

(Prerequisite: ZEDS –A3-3)

ZEDS-A4: Conduct a study to determine which methods are most affordable for achieving QOS Requirements.

ZEDS –A4-1: Conduct a study to determine different methods to achieve different levels of QOS. Perform Concept Designs of candidate methods and perform dynamic simulations to verify effectiveness.

(Prerequisite: none)

ZEDS –A4-2: Conduct a design space study to determine which of the effective methods identified in ZEDS-A4-1 are most cost effective when integrated into ship systems.

(Prerequisite: ZEDS –A4-1)

Deadline B:

ZEDS-B1: Demonstrate and test a Full Scale demonstration of ZEDS system employing PCM-1A, PCM-2A, and if necessary, a new PCM-4.

(As needed to support acquisition)

Deadline C:

ZEDS-C1: Demonstrate and test a Full Scale demonstration of IFTP system employing improved efficiency PCM-2A power modules and communications over the power line.

(As needed to support acquisition)

E.5 Power Generation Modules (PGM)

Deadline A:

PGM-A1: New higher power ATG based on high frequency AC generation with power electronics to produce 60 Hz. power to support near term CG(X). New PGM must fit in same footprint as existing ATG on DDG-1000.

PGM-A1-1: Design, build, test, new ATG for use on CG(X)

(Prerequisite: None)

PGM-A1-2: Develop a performance specification for new ATG for use on CG(X)

(Prerequisite: PGM-A1-1)

Deadline B:

PGM-B1: Develop and document a method for paralleling of HFAC generators.

PGM-B1-1: Conduct a market survey and analytic study to develop proposed methods for paralleling HFAC generators.

(Prerequisite: none)

PGM-B1-2: Conduct testing to validate proposed methods to parallel HFAC generators.

(Prerequisite: PGM-B1-1)

- PGM-B2: Develop 4-10 MW generator for 1800 rpm operation suitable for MVDC applications and if necessary, HFAC operation
(As needed to support acquisition)
- PGM-B3: Develop 20 to 40 MW scalable generator for 3600 rpm operation suitable for MVDC applications and if necessary, HFAC operation
(As needed to support acquisition)
- PGM-B4: Develop 4-10 MW scalable generator for 7200 rpm operation suitable for MVDC applications and if necessary, HFAC operation
(As needed to support acquisition)
- PGM-B5: Develop scalable generator for steam turbine operation suitable for MVDC applications and if necessary, HFAC operation
(As needed to support acquisition)
- PGM-B6: Develop scalable rectifier for MVDC applications.
(As needed to support acquisition)
- PGM-B6-1: Conduct a study to determine different methods to implement a scalable and open architecture rectifier for MVDC PGM applications. Perform Concept Designs of candidate methods and perform dynamic simulations to verify effectiveness.
(Prerequisite: None)
- PGM-B6-2: Conduct a design space study to determine which of the effective methods identified in PGM-B6-1 are most cost effective when integrated into ship systems.
(Prerequisite: PGM-B6-1)
- PGM-B6-3: Design, Build, and Test one or more Advanced Development Model(s) demonstrating the cost effective solutions identified in PGM-B6-2.
(Prerequisite: PGM-B6-2)
- PGM-B6-4: Develop a Performance Specification for an open scalable rectifier for MVDC PGM applications.
(Prerequisite: PGM-B6-3)

Deadline C:

- PGM-C1: Develop and/or update standards, design data sheets, design tools, and design data to provide consistency in the design and integration into ship designs of power systems employing Fuel Cell Power Generation Modules.

- PGM-C1-1: Update Power Generation System Design and Integration Handbook to incorporate Fuel Cells
(Prerequisite: none)
- PGM-C1-2: Update ASSET to incorporate Fuel Cells
(Prerequisite: PGM-C2)
- PGM-C1-3: Develop and maintain Module Characterization Sheets for Fuel Cell PGMs.
Prerequisite: PGM-C2)
- PGM-C1-4: Update Naval Vessel Rules
(Prerequisite: PGM-C1-1)
- PGM-C1-5: Update GENSPECS for Overhauls
(Prerequisite: PGCM-C1-1)
- PGM-C1-6: Develop Performance Specification for Fuel Cell based PGM
(Prerequisite: PGM-C2)
- PGM-C1-7: Develop a Software Requirements Document for the PCON Module required to support Fuel Cells.
(Prerequisite: PGM-C2)

- PGM-C2: Develop and Demonstrate at full scale, a modular and scalable fuel cell that can employ Navy logistics fuels and produce power with the power quality and dynamic response needed by the NGIPS distribution modules.
 - PGM-C2-1: Conduct a study to determine different methods to implement an open architecture Fuel Cell based Power Generation Modules. Perform Concept Designs of candidate methods and perform dynamic simulations to verify effectiveness.
(Prerequisite: none)
 - PGM-C2-2: Conduct a design space study to determine which of the effective methods identified in PGM-C2-1 are most cost effective when integrated into ship systems.
(Prerequisite: PGM-C2-1)
 - PGM-C2-3: Design, Build, and Test one or more Advanced Development Model(s) demonstrating the cost effective solutions identified in PGM-C2-2.
(Prerequisite: PGM-C2-2)

E.6 Propulsion Motor Modules (PMM)

Deadline A:

PMM-A1: New Propulsion Motor and Drive based on either permanent magnet motor technology or advanced superconducting technology to interface on MVAC to support near term CG(X)

PMM-A1-1: Design, build, test, new propulsion motor and drive for use on CG(X)
(Prerequisite: None)

PMM-A1-2: Develop a performance specification for new propulsion motor and drive for use on CG(X)
(Prerequisite: PMM-A1-1)

Deadline B:

PMM-B1: Develop a design standard and guidance for integrating electric propulsion motors with mechanical drive prime movers.

PMM-B1-1: Perform a study to determine the conditions under which a hybrid drive is beneficial. Develop Design Guidance.
(Prerequisite: none)

PMM-B1-2: Develop a Hybrid Drive Performance Specification
(Prerequisite: PMM-B1-1)

PMM-B1-3: Update Mobility System Design and Integration Handbook
(Prerequisite: PMM-B1-1)

PMM-B2: Develop and/or update standards, design data sheets, design tools, and design data. to provide consistency in the design of forward propulsors across ship classes

PMM-B2-1: Update Mobility System Design and Integration Handbook to include forward propulsors (Prerequisite: none)

PMM-B2-2: Update ASSET to incorporate Forward Propulsors
(Prerequisite: PMM-B2-1)

PMM-B2-3: Develop and maintain Module Characterization Sheets for Forward Propulsors.
(As required)

PMM-B2-4: Update Naval Vessel Rules
(Prerequisite: PMM-B2-1)

PMM-B2-5: Update GENSPECS for Overhauls
(Prerequisite: PMM-B2-1)

PMM-B2-6: Develop a Software Requirements Document for the PCON
Module required to support Forward Propulsor.
(Prerequisite: PMM-B2-1)

PMM-B3: Develop and demonstrate a quiet, shock hardened, efficient retractable
forward pod capable of propelling a ship at a tactically useful speed.

PMM-B3-1: Conduct a study to determine different methods to implement a
quiet, shock hardened, efficient retractable pod that is scalable for
different ship applications. Perform Concept Designs of candidate
methods and perform dynamic simulations to verify effectiveness.
(Prerequisite: none)

PMM-B3-2: Conduct a design space study to determine which of the effective
methods identified in PMM-B3-1 are most cost effective when
integrated into ship systems.
(Prerequisite: PMM-B3-1)

PMM-B3-3: Design, Build, and Test one or more Advanced Development
Model(s) demonstrating the cost effective solutions identified in
PMM-B3-2.
(Prerequisite: PMM-B3-2)

PMM-B3-4: Develop a retractable forward pod performance specification.
(Prerequisite: PMM-B3-3)

Deadline C:

PMM-C1: Develop and/or update standards, design data sheets, design tools, and
design data. to provide consistency in the design of aft podded propulsors
as a part of contra-rotating propulsion systems.

PMM-C1-1: Update Mobility System Design and Integration Handbook to
include aft podded propulsors
(Prerequisite: none)

PMM-C1-2: Update ASSET to incorporate aft podded Propulsors
(Prerequisite: PMM-C1-1)

PMM-C1-3: Develop and maintain Module Characterization Sheets for aft
podded Propulsors.
(As required)

- PMM-C1-4: Update Naval Vessel Rules
(Prerequisite: PMM-C1-1)
- PMM-C1-5: Update GENSPECS for Overhauls
(Prerequisite: PMM-C1-1)
- PMM-C1-6: Develop a Software Requirements Document for the PCON
Module required to support aft podded Propulsor.
(Prerequisite: PMM-C1-1)
- PMM-C2: Develop and demonstrate an aft steerable podded propulsion as part of
contra-rotation for improved efficiency. First application should target
combat logistics force ship.
 - PMM-C2-1: Conduct a study to determine different methods to implement a
quiet, shock hardened, efficient aft steerable podded propulsor that
is scalable for different ship applications and suitable for
incorporation into a contra-rotation system. Perform Concept
Designs of candidate methods and perform dynamic simulations to
verify effectiveness.
(Prerequisite: none)
 - PMM-C2-2: Conduct a design space study to determine which of the effective
methods identified in PMM-C2-1 are most cost effective when
integrated into ship systems.
(Prerequisite: PMM-C2-1)
 - PMM-C2-3: Design, Build, and Test one or more Advanced Development
Model(s) demonstrating the cost effective solutions identified in
PMM-C2-2.
(Prerequisite: PMM-C2-2)
 - PMM-C2-4: Develop a aft steerable podded propulsor performance
specification.
(Prerequisite: PMM-C2-3)
- PMM-C3: Develop affordable methods to reduce Propulsion Motor Drive induced
current harmonics without using 60 Hz. transformers. Possible methods
include active rectification and advanced filters.
 - PMM-C3-1: Conduct a study to determine different methods to reduce current
harmonics. Perform Concept Designs of candidate methods and
perform dynamic simulations to verify effectiveness.
(Prerequisite: none)

PMM-C3-2: Conduct a design space study to determine which of the effective methods identified in PMM-C3-1 are most cost effective when integrated into ship systems.

(Prerequisite: PMM-C3-1)

PMM-C3-3: Design, Build, and Test one or more Advanced Development Model(s) demonstrating the cost effective solutions identified in PMM-C3-2.

(Prerequisite: PMM-C3-2)

PMM-C4: Develop an open architecture motor drive common across ship classes.

PMM-C4-1: Conduct a study to determine different methods to implement an open architecture motor drive that employs modular, efficient, power dense power converters interfacing to MVAC, HFAC, and MVDC busses. Perform Concept Designs of candidate methods and perform dynamic simulations to verify effectiveness.

(Prerequisite: None)

PMM-C4-2: Conduct a design space study to determine which of the effective methods identified in PMM-C4-1 are most cost effective when integrated into ship systems.

(Prerequisite: PMM-C4-1)

PMM-C4-3: Design, Build, and Test one or more Advanced Development Model(s) demonstrating the cost effective solutions identified in PMM-C4-2.

(Prerequisite: PMM-C4-2)

PMM-C4-4: Develop an open architecture motor drive performance specification.

(Prerequisite: PMM-C4-3)

E.7 Power Load Module (PLM)

Deadline A:

None

Deadline B:

None

Deadline C:

PLM-C1: Develop and/or update standards, design data sheets, design tools, and design data to provide consistency in the design of power systems to support Pulse Power applications.

PLM-C1-1: Update Design and Integration Handbooks
(Prerequisite: none)

PLM-C1-2: Update ASSET to incorporate updated Design and Integration Handbooks
(Prerequisite: PLM-C1-1)

PLM-C1-3: Develop and maintain Module Characterization Sheets for modules needed for Pulse Power Support
(As required)

PLM-C1-4: Update Naval Vessel Rules
(Prerequisite: PLM-C1-1)

PLM-C1-5: Update GENSPECS for Overhauls
(Prerequisite: PLM-C1-1)

PLM-C1-6: Update Module Performance Specifications
(As needed, Prerequisite: PLM-C1-1)

PLM-C2 Demonstrate support for Pulse Power applications at full scale.

PLM-C2-1: Conduct a study to determine different methods to implement Pulse Power support within NGIPS. Perform Concept Designs of candidate methods and perform dynamic simulations to verify effectiveness.
(Prerequisite: none)

PLM-C2-2: Conduct a design space study to determine which of the effective methods identified in PLM-C2-1 are most cost effective when integrated into ship systems.

(Prerequisite: PLM-C2-1)

PLM-C2-3: Design, Build, and Test one or more Advanced Development Model(s) demonstrating the cost effective solutions identified in PLM-C2-2.

(Prerequisite: PLM-C2-2)

E.8 Power Distribution Modules (PDM)

Deadline A:

PDM-A1: Develop and demonstrate a Controllable Bus Transfer (CBT) for use in ZEDS.

PDM-A1-1: Conduct a study to determine different methods to implement a Controllable bus transfer (CBT) for use in providing AC loads with redundant sources of power in ZEDS. Perform Concept Designs of candidate methods and perform dynamic simulations to verify effectiveness.

(Prerequisite: none)

PDM-A1-2: Conduct a design space study to determine which of the effective methods identified in PDM-A1-1 are most cost effective when integrated into ship systems.

(Prerequisite: PDM-A1-1)

PDM-A1-3: Design, Build, and Test one or more Advanced Development Model(s) demonstrating the cost effective solutions identified in PDM-A1-2.

(Prerequisite: PDM-A1-2)

PDM-A1-4: Develop a CBT performance specification.

(Prerequisite: PDM-A1-3)

Deadline B:

PDM-B1: Develop derating guidance and/or test procedures for switchgear operating at HFAC.

PDM-B1-1: Conduct a market survey and analytic study to develop proposed derating guidance and test procedures for switchgear operating at HFAC.

(Prerequisite: none)

- PDM-B1-2: Conduct testing to validate derating guidance and test procedures, update proposed derating guidance and test procedures
(Prerequisite: PDM-B1-1)
- PDM-B2: Develop derating guidance and/or test procedures for cables operating at HFAC.
- PDM-B2-1: Conduct a market survey and analytic study to develop proposed derating guidance and test procedures for cable operating at HFAC.
(Prerequisite: none)
- PDM-B2-2: Conduct testing to validate derating guidance and test procedures, update proposed derating guidance and test procedures
(Prerequisite: PDM-B2-1)
- PDM-B3: Develop and qualify for naval use distribution system instrumentation operating at HFAC.
- PDM-B3-1: Conduct a study to determine different methods to implement distribution system instrumentation on HFAC. Perform Concept Designs of candidate methods and perform dynamic simulations to verify effectiveness.
(Prerequisite: None)
- PDM-B3-2: Conduct a design space study to determine which of the effective methods identified in PDM-B3-1 are most cost effective when integrated into ship systems.
(Prerequisite: PDM-B3-1)
- PDM-B3-3: Design, Build, and Test one or more Advanced Development Model(s) demonstrating the cost effective solutions identified in PDM-B3-2.
(Prerequisite: PDM-B3-2)
- PDM-B4: Develop and document cable installation methods for operation at HFAC.
- PDM-B4-1: Conduct a market survey and analytic study to develop proposed cable installation methods for cable operating at HFAC.
(Prerequisite: none)
- PDM-B4-2: Conduct testing to validate proposed cable installation methods.
(Prerequisite: PDM-B4-1)

Deadline C:

- PDM-C1: Develop and qualify for naval use affordable MVDC switchgear
 - PDM-C1-1: Conduct a study to determine different methods to implement MVDC switchgear. Perform Concept Designs of candidate methods and perform dynamic simulations to verify effectiveness.
(Prerequisite: none)
 - PDM-C2-2: Conduct a design space study to determine which of the effective methods identified in PDM-C2-1 are most cost effective when integrated into ship systems.
(Prerequisite: PDM-C2-1)
 - PDM-C2-3: Design, Build, and Test one or more Advanced Development Model(s) demonstrating the cost effective solutions identified in PDM-C2-2.
(Prerequisite: PDM-C2-2)
 - PDM-C2-4: Develop a Performance Specification for MVDC switchgear.
(Prerequisite: PDM-C2-3)

E.9 Power Conversion Modules (PCM)

Deadline A:

None

Deadline B:

- PCM-B1: Develop and test an open architecture and scalable Shore Power interface that can interface with either an HFAC or MVDC power distribution system.
 - PCM-B1-1: Conduct a study to determine different methods to implement an open architecture and scalable Shore Power Interface on HFAC or MVDC. Perform Concept Designs of candidate methods and perform dynamic simulations to verify effectiveness.
(Prerequisite: None)
 - PCM-B1-2: Conduct a design space study to determine which of the effective methods identified in PCM-B1-1 are most cost effective when integrated into ship systems.
(Prerequisite: PCM-B1-1)

- PCM-B1-3: Design, Build, and Test one or more Advanced Development Model(s) demonstrating the cost effective solutions identified in PCM-B1-2.
(Prerequisite: PCM-B1-2)
- PCM-B1-4: Develop a Performance Specification for an open architecture and scalable Shore Power interface for HFAC and MVDC applications.
(Prerequisite: PCM-B1-3)
- PCM-B2: Develop and demonstrate PCM-1A as an open architecture module suitable for surface ship and submarine applications.
- PCM-B2-1: Conduct a study to determine different methods to implement a PCM-1a as an open architecture module suitable for surface ships and submarines. Perform Concept Designs of candidate methods and perform dynamic simulations to verify effectiveness.
(Prerequisite:)
- PCM-B2-2: Conduct a design space study to determine which of the effective methods identified in PCM-B2-1 are most cost effective when integrated into ship systems.
(Prerequisite: PCM-B2-1)
- PCM-B2-3: Design, Build, and Test one or more Advanced Development Model(s) demonstrating the cost effective solutions identified in PCM-B2-2.
(Prerequisite: PCM-B2-2)
- PCM-B2-4: Develop a PCM-1A, SSIM, SSCM performance specification.
(Prerequisite: PCM-B2-3)
- PCM-B3: Develop and demonstrate PCM-2A as an open architecture module suitable for surface ship and submarine applications. Base the PCM-2A on the IPNC performance specification.
- PCM-B3-1: Conduct a study to determine different methods to implement a PCM-2a as an open architecture module suitable for surface ships and submarines. Perform Concept Designs of candidate methods and perform dynamic simulations to verify effectiveness.
(Prerequisite: none)
- PCM-B3-2: Conduct a design space study to determine which of the effective methods identified in PCM-B3-1 are most cost effective when integrated into ship systems.
(Prerequisite: PCM-B3-1)

PCM-B3-3: Design, Build, and Test one or more Advanced Development Model(s) demonstrating the cost effective solutions identified in PCM-B3-2.

(Prerequisite: PCM-B3-2)

PCM-B3-4: Develop a PCM-2A and power module performance specification.

(Prerequisite: PCM-B3-3)

PCM-B4: Determine and document whether incorporating PCM-4 functionality into PCM-1A or keeping a centralized PCM-4 (current design) is the preferred architecture for interfacing with MVAC, MVDC, and HFAC power generation systems. If necessary, develop and demonstrate a PCM-4 able to interface with HFAC and/or MVDC.

PCM-B4-1: Conduct a study to determine different methods to implement PCM-4 functionality suitable for surface ships and submarines. Perform Concept Designs of candidate methods and perform dynamic simulations to verify effectiveness.

(Prerequisite: none)

PCM-B4-2: Conduct a design space study to determine which of the effective methods identified in PCM-B4-1 are most cost effective when integrated into ship systems.

(Prerequisite: PCM-B4-1)

PCM-B4-3: If necessary, design, build, and test one or more Advanced Development Model(s) demonstrating the cost effective solutions identified in PCM-B4-2.

(Prerequisite: PCM-B4-2)

PCM-B4-4: If necessary, develop a PCM-4 performance specification.

(Prerequisite: PCM-B4-3)

Deadline C:

PCM-C1: Develop affordable methods to reduce acoustic signature and vibration of 60 Hz. Power Transformers.

PCM-C1-1: Conduct a study to determine different methods to reduce acoustic signature and vibration of 60 Hz. Power Transformers. Perform Concept Designs of candidate methods and perform Finite Element Analysis and dynamic simulations to verify effectiveness.

(Prerequisite: None)

- PCM-C1-2: Conduct a design space study to determine which of the effective methods identified in PCM-C1-1 are most cost effective when integrated into ship systems.
(Prerequisite: PCM-C1-1)
- PCM-C1-3: Design, Build, and Test one or more Advanced Development Model(s) demonstrating the cost effective solutions identified in PCM-C1-2.
(Prerequisite: PCM-C1-2)
- PCM-C1-4: Update Performance Specification for 60 Hz. Power Transformers.
(Prerequisite: PCM-C1-3)
- PCM-C2: Improve the efficiency of the PCM-2A power modules.
- PCM-C2-1: Conduct a study to determine different methods to improve the efficiency of PCM-2A power modules. Perform Concept Designs of candidate methods and perform dynamic simulations to verify effectiveness.
(Prerequisite: none)
- PCM-C2-2: Conduct a design space study to determine which of the effective methods identified in PCM-C2-1 are most cost effective when integrated into ship systems.
(Prerequisite: PCM-C2-1)
- PCM-C2-3: Design, Build, and Test one or more Advanced Development Model(s) demonstrating the cost effective solutions identified in PCM-C2-2.
(Prerequisite: PCM-C2-2)
- PCM-C2-4: Update power module performance specifications.
(Prerequisite: PCM-C2-3)
- PCM-C3: Integrate communications over the power line into the PCM-2A power output modules. Consider the use of IEEE P1901 for Broadband over Power Line Networks.
- PCM-C3-1: Conduct a study to determine different methods to integrate communications over the power line into PCM-2A power modules. Perform Concept Designs of candidate methods and perform dynamic simulations to verify effectiveness.
(Prerequisite: none)

- PCM-C3-2: Conduct a design space study to determine which of the effective methods identified in PCM-C3-1 are most cost effective when integrated into ship systems.
(Prerequisite: PCM-C3-1)
- PCM-C3-3: Design, Build, and Test one or more Advanced Development Model(s) demonstrating the cost effective solutions identified in PCM-C3-2.
(Prerequisite: PCM-C3-2)
- PCM-C3-4: Update power module performance specifications.
(Prerequisite: PCM-C3-3)
- PCM-C4: Integrate communications over the power line into the PCM-1A SSIMs and SSCMs.
- PCM-C4-1: Conduct a study to determine different methods to integrate communications over the power line into PCM-1A power modules (SSIM and SSCM). Perform Concept Designs of candidate methods and perform dynamic simulations to verify effectiveness.
(Prerequisite: none)
- PCM-C4-2: Conduct a design space study to determine which of the effective methods identified in PCM-C4-1 are most cost effective when integrated into ship systems.
(Prerequisite: PCM-C4-1)
- PCM-C4-3: Design, Build, and Test one or more Advanced Development Model(s) demonstrating the cost effective solutions identified in PCM-C4-2.
(Prerequisite: PCM-C4-2)
- PCM-C4-4: Update power module performance specifications.
(Prerequisite: PCM-C4-3)
- PCM-C5: Develop a standard load interface unit to enable loads to employ communications over the power line for machinery control applications.
- PCM-C5-1: Conduct a study to determine different methods to implement a standard load interface unit to enable loads to employ communications over the power line. Perform Concept Designs of candidate methods and perform dynamic simulations to verify effectiveness.
(Prerequisite: PCM-C3-1, PCM-C4-1)

- PCM-C5-2: Conduct a design space study to determine which of the effective methods identified in PCM-C5-1 are most cost effective when integrated into ship systems.
(Prerequisite: PCM-C5-1)
- PCM-C5-3: Design, Build, and Test one or more Advanced Development Model(s) demonstrating the cost effective solutions identified in PCM-C5-2.
(Prerequisite: PCM-C5-2)
- PCM-C5-4: Develop a standard Communications over the Power Line load interface unit performance specification.
(Prerequisite: PCM-C5-3)

E.10 Energy Storage Module (ESM)

Deadline A:

- ESM-A1: Study and Report if an ESM can contribute to ship affordability
(Prerequisite: None)
- ESM-A2: If affordable, develop and document an open architecture approach for ESM Development
(Prerequisite: ESM-A1)
- ESM-A3: If affordable, Develop and Test an ESM (Possibly defer to Deadline B)
 - ESM-A3-1: Conduct a study to determine different methods to implement an open architecture Energy Storage Module. Perform Concept Designs of candidate methods and perform dynamic simulations to verify effectiveness.
(Prerequisite: none)
 - ESM-A3-2: Conduct a design space study to determine which of the effective methods identified in ESM-A3-1 are most cost effective when integrated into ship systems.
(Prerequisite: ESM-A3-1)
 - ESM-A3-3: Design, Build, and Test one or more Advanced Development Model(s) demonstrating the cost effective solutions identified in ESM-A3-2.
(Prerequisite: ESM-A3-2)
 - ESM-A3-4: Develop an ESM performance specification.
(Prerequisite: ESM-A3-3)

ESM-A4: Develop and/or update standards, design data sheets, design tools, and design data to provide consistency in the design of power systems employing Energy Storage Modules. (Possibly defer to Deadline B)

ESM-A4-1: Update Power Generation System Design and Integration Handbook to incorporate Energy Storage Modules
(Prerequisite: none)

ESM-A4-2: Update ASSET to incorporate ESM
(Prerequisite: ESM-A3)

ESM-A4-3: Develop and maintain Module Characterization Sheets for ESMs.
(Prerequisite: ESM-A3)

ESM-A4-4: Update Naval Vessel Rules
(Prerequisite: ESM-A4-1)

ESM-A4-5: Update GENSPECS for Overhauls
(Prerequisite: ESM-A4-1)

ESM-A4-6: Develop a Software Requirements Document for the PCON Module required to support ESM.
(Prerequisite: ESM-A4-1)

Deadline B:

None

Deadline C:

ESM-C1 Develop and/or update standards, design data sheets, design tools, and design data to provide consistency in the design of power systems employing Energy Storage Modules for Pulse Power support that can also enable single engine cruise operation.

ESM-C1-1: Update Power Generation System Design and Integration Handbook to incorporate Energy Storage Modules
(Prerequisite: none)

ESM-C1-2: Update ASSET to incorporate ESM
(Prerequisite: ESM-C2)

ESM-C1-3: Develop and maintain Module Characterization Sheets for ESMs.
(Prerequisite: ESM-C2)

- ESM-C1-4: Update Naval Vessel Rules
(Prerequisite: ESM-C1-1)
- ESM-C1-5: Update GENSPECS for Overhauls
(Prerequisite: ESM-C1-1)
- ESM-C1-6: Develop a Software Requirements Document for the PCON Module required to support ESM.
(Prerequisite: ESM-C1-1)
- ESM-C2 Develop and Demonstrate at full-scale, an intermediate energy storage solution for Pulse Power applications that can also enable single engine cruise operation.
 - ESM-C2-1: Conduct a study to determine different methods to implement an open architecture Energy Storage Module suitable for Pulse Power applications that can also enable single engine cruise operation. Perform Concept Designs of candidate methods and perform dynamic simulations to verify effectiveness.
(Prerequisite: none)
 - ESM- C2-2: Conduct a design space study to determine which of the effective methods identified in ESM-C2-1 are most cost effective when integrated into ship systems.
(Prerequisite: ESM- C2-1)
 - ESM- C2-3: Design, Build, and Test one or more Advanced Development Model(s) demonstrating the cost effective solutions identified in ESM-C2-2.
(Prerequisite: ESM- C2-2)
 - ESM- C2-4: Update the ESM performance specification.
(Prerequisite: ESM- C2-3)

E.11 Power Control Module (PCON)

- PCON-1: Develop and/or update standards, design data sheets, design tools, and design data to provide consistency in the design of power control modules for IPS.
 - PCON-1-1: Update Design and Integration Handbooks
(Prerequisite: PCON-A3)
 - PCON-1-2: Update ASSET to incorporate updated Design and Integration Handbooks
(Prerequisite: PCON-1-1)

- PCON-1-3: Develop and maintain Module Characterization Sheets to reflect PCON open architecture
(As required)
- PCON-1-4: Update Naval Vessel Rules
(Prerequisite: PCON-1-1)
- PCON-1-5: Update GENSPECS for Overhauls
(Prerequisite: PCON-1-1)
- PCON-1-6: Update Module Performance Specifications
(As needed, Prerequisite: PCON-A2-1)

Deadline A:

- PCON-A1: Develop and Document a PCON open architecture
 - PCON-A1-1: Conduct a study to determine different methods to implement an open architecture PCON Module. Perform Concept Designs of candidate methods and perform dynamic simulations to verify effectiveness.
(Prerequisite: none)
 - PCON-A1-2: Conduct a design space study to determine which of the effective methods identified in PCON-A1-1 are most cost effective when integrated into ship systems.
(Prerequisite: PCON-A1-1)
 - PCON-A1-3: Develop Software Design Documentation and Software Requirements Documentation to implement the open architecture PCON
(Prerequisite: PCON-A1-2)
- PCON-A2: Develop and demonstrate an open architecture PCON software implementation to support MVAC, HFAC, and ZEDS that includes the following functionality:
 - c. Remote Monitoring and Control of NGIPS modules
 - d. Mobility Control
 - e. Resource Planning, System Configuration and Mission Priority Load Shedding
 - f. Fault Detection , Fault Isolation, QOS Load Shedding
- PCON-A2-1: Design PCON Software
(Prerequisite: PCON-A1)

PCON-A2-2: Develop and Test PCON configuration items
(Prerequisite: PCON-A2-1)

PCON-A2-3: Integrate configuration items into a PCON module and test
(Prerequisite: PCON-A2-2)

PCON-A2-4: Establish a PCON development, maintenance and test facility
(Prerequisite: PCON-A1)

Deadline B:

PCON-B1: Develop and demonstrate an open architecture PCON software implementation to support MVAC, HFAC, and ZEDS that adds the following functionality:
g. Maintenance Support
h. Training

PCON-B1-1: Design PCON Software
(Prerequisite: PCON-A2)

PCON-B1-2: Develop and Test PCON configuration items
(Prerequisite: PCON-B1-1)

PCON-B1-3: Integrate configuration items into a PCON module and test
(Prerequisite: PCON-B1-2)

Deadline C:

PCON-C1 Extend and demonstrate an open architecture PCON software implementation to additionally support MVDC.

PCON-C1-1: Design PCON Software
(Prerequisite: PCON-B1)

PCON-C1-2: Develop and Test PCON configuration items
(Prerequisite: PCON-C1-1)

PCON-C1-3: Integrate configuration items into a PCON module and test
(Prerequisite: PCON-C1-2)

E.12 Systems Architecting and Engineering

- SYSE-1 Develop and maintain alternate future fleet force architectures to support commonality studies for years 2030, 2045, and 2060. Derive energy usage profiles, including uncertainty analysis, for each alternate fleet.
(Prerequisite: none)
- SYSE-2 Develop and maintain reference power system designs, including uncertainty analysis, to support ship concept studies.
(Prerequisite: none)
- SYSE-3 Develop and maintain a product oriented cost model for NGIPS systems that incorporates uncertainty analysis.
(Prerequisite: none)
- SYSE-4 Develop and maintain a reference machinery system concept of operations.
(Prerequisite: none)
- SYSE-5 Develop and maintain a validated and verified Simulation Environment with associated dynamic models to support preliminary and contract design of NGIPS systems, interface specification development, as well as integration studies with special loads (i.e. pulse power).
(Prerequisite: none)
- SYSE-6 Identify and Track NGIPS risks
(Prerequisite: none)
- SYSE-7 Develop and Maintain a NGIPS knowledge management system
(Prerequisite: none)