

MVDC for future warships

ASNE Technology Systems & Ships 2017

February 14-16, 2017

Crystal City, VA

IPES: Power and Energy as the Foundation of the Kill Chain

Dr. Norbert Doerry

Why Medium Voltage DC?

- Decouple prime mover speed from power quality
 - Minimize energy storage
 - Avoids large currents to restore synchronism (in a.c. systems) during disturbances / pulses.
- Power conversion can operate at high frequency – Improve power density
- Potentially less aggregate power electronics
 - Share rectification stages
- Cable ampacity does not depend on power factor or skin effect
- Power Electronics can control fault currents
 - Use disconnects instead of circuit breakers
- Acoustic Signature improvements
- Easier and faster paralleling of generators
 - May reduce energy storage requirements
- Ability to use high speed power turbines on gas turbines

Affordably meet electrical power demands of future destroyer

An AC Integrated Power System would likely require future destroyer to displace greater than 10,000 mt

MVDC Reference Architecture

Overarching Active Power Management and Controls

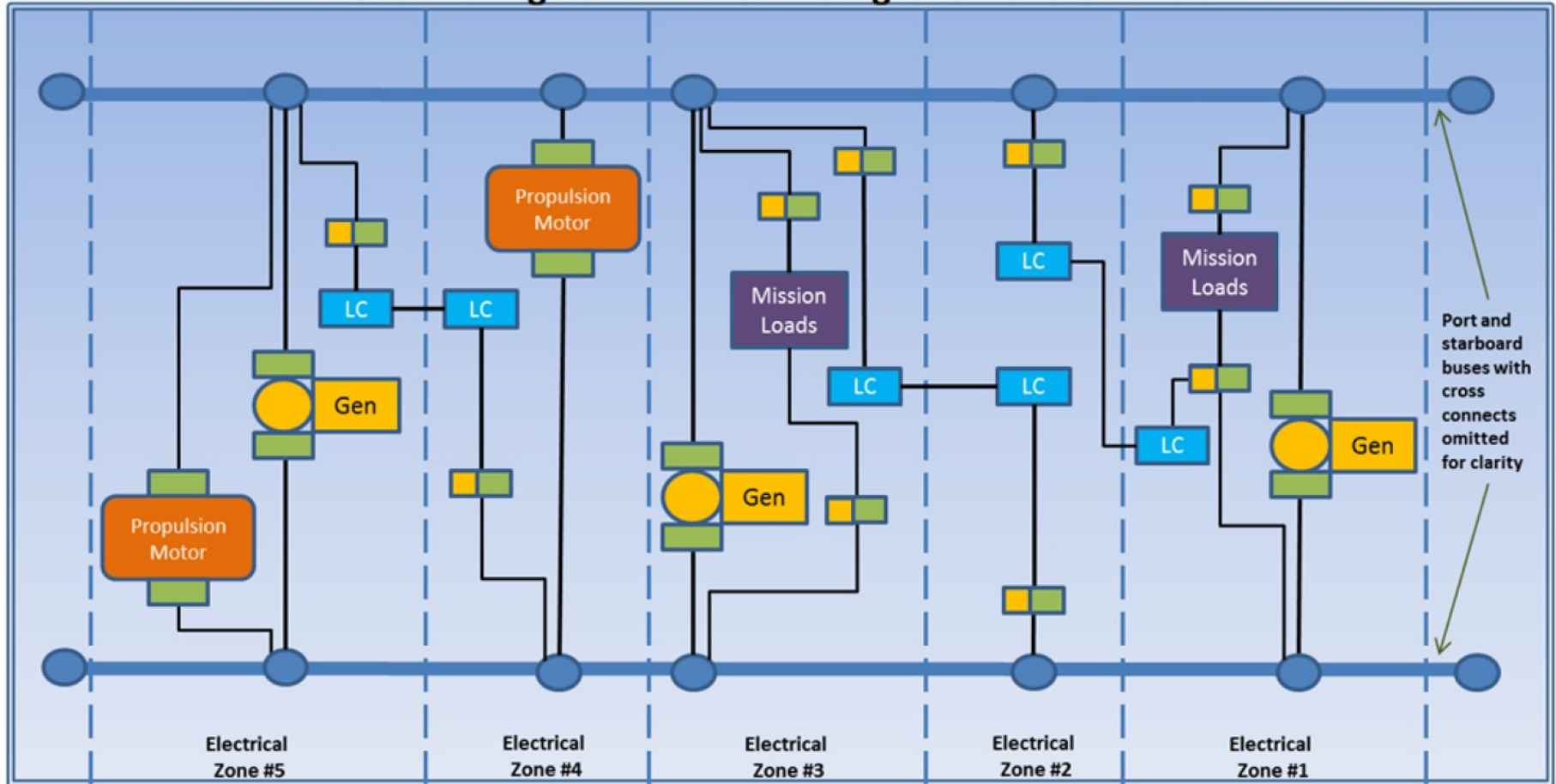

Port and starboard buses with cross connects omitted for clarity

MVDC Voltage Standards

- MVDC nominal voltages based on IEEE 1709
 - 6000 VDC
 - 12000 VDC
 - 18000 VDC
- Current levels and Power Electronic Devices constrain voltage selection
 - 4000 amps is practical limit for mechanical switches
 - Power electronic device voltages increasing with time
 - SiC will lead to great increase
- For now, 12000 VDC appears a good target ...
 - 4000 amps per bus enables 96 MW on 2 buses
- Power Quality requirements TBD
 - MIL-STD-1399 section under development

Bus Nodes

- Segment MVDC Bus
 - Disconnects
- Isolate loads
 - Disconnects
- Isolate sources
 - Breaker
 - Disconnect if Breaker functionality in source
- Establishes Ground Reference for MVDC Bus
 - If functionality not provided in source

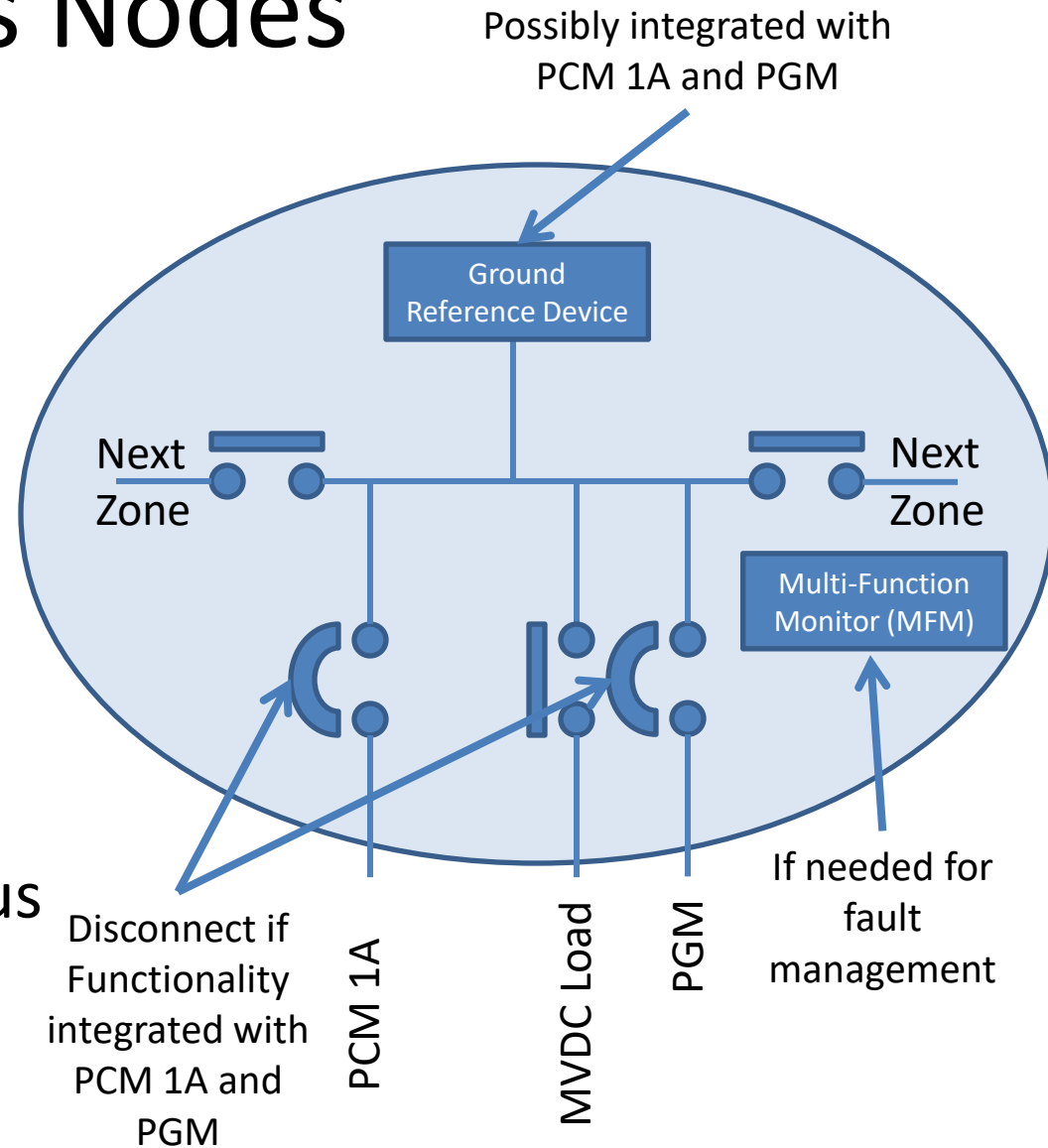

Power Generation Modules

- Split Windings
 - Reduced Impact on prime mover due to fault on one MVDC bus
 - Simplifies “odd number of generators” dilemma
 - May enable reducing ampacity of MVDC bus
- Consider Fuel Cells in the future

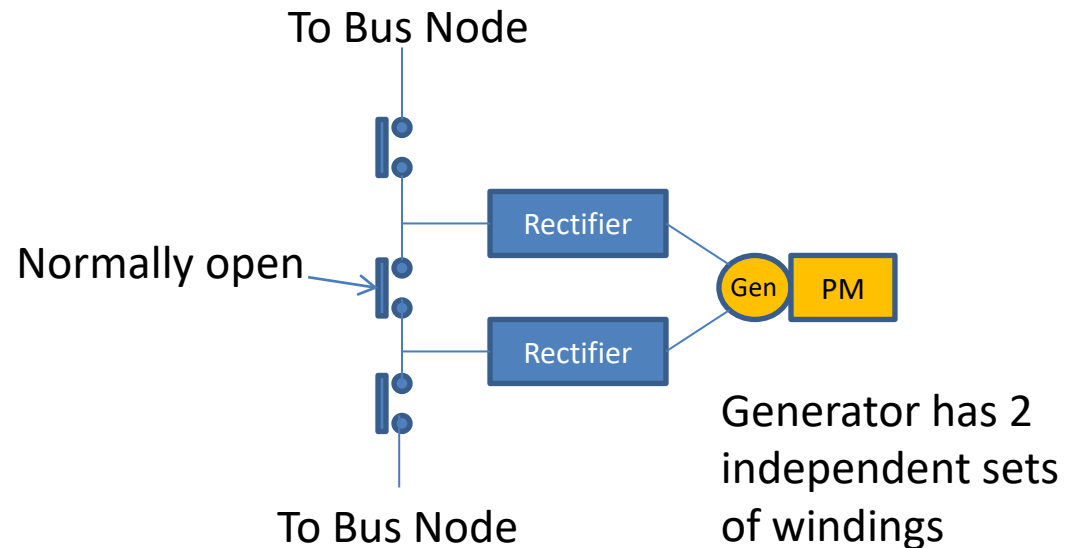
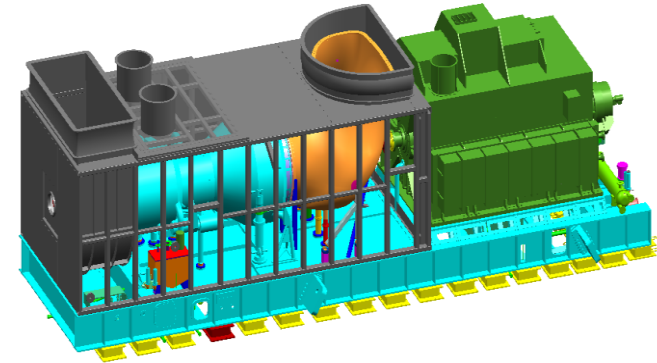

Propulsion Motor Modules

- Typically two motors for reliability
 - May share housing
- Normally powered by both MVDC busses
- Requires control interface for load management
- Consider contra-rotating propellers for fuel efficiency and minimizing installed electrical power generation capacity

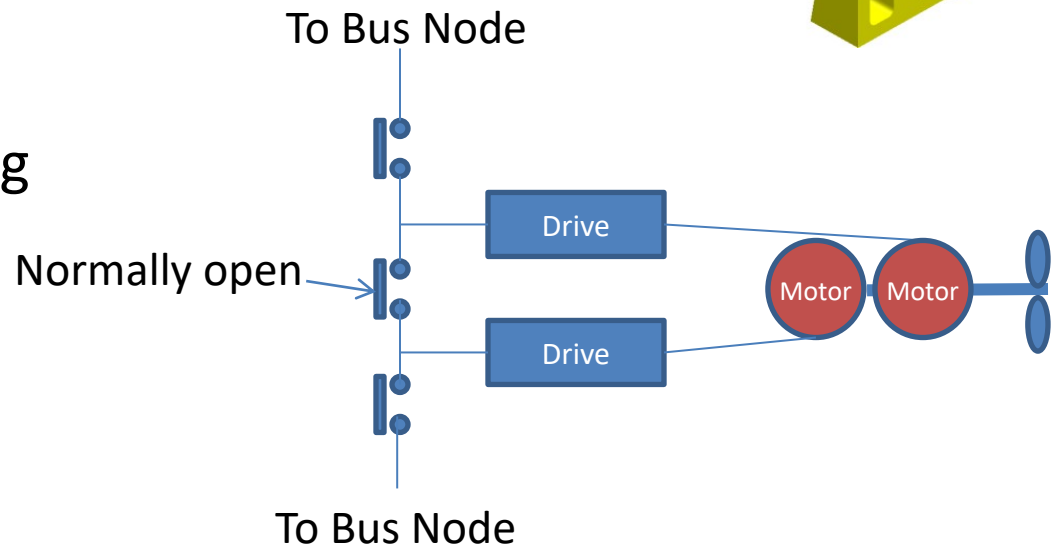
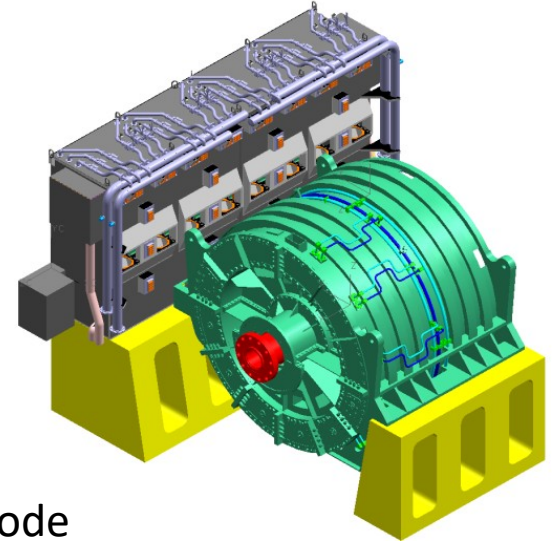

PCM-1A – Energy Magazine

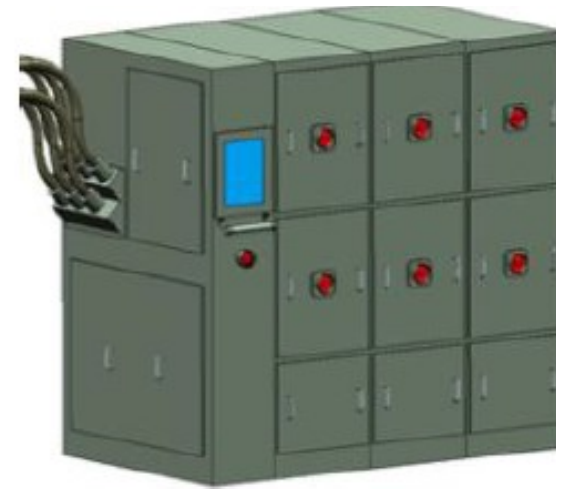
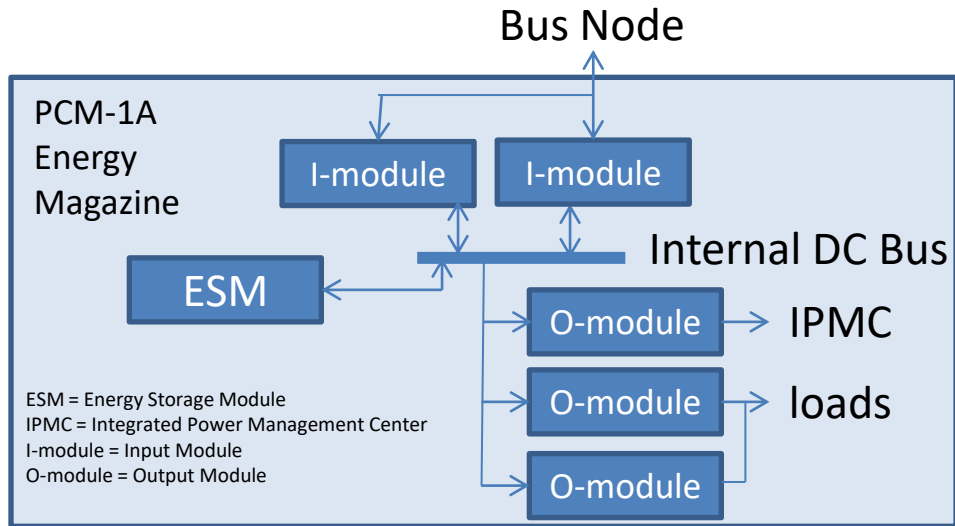

- Protects the MVDC bus from in-zone faults
- Provides hold up power while clearing faults on the MVDC Bus
- If desired ...
 - provides hold up power while standby generator starts
 - contributes to energy storage for pulse power loads
 - acts as an active filter to reduce current harmonics/ripple
- Provides conditioned power to loads
 - AC interfaces as defined in MIL-STD-1399 section 300
 - Low Voltage DC interfaces under development (New MIL-STD-1399 section)
- Provides power to loads up to several MW (Lasers, Radars, Electronic Warfare)
- Provides power to “down-stream” power conversion (IPMC)
- Near term applications use I-modules with AC inputs: “Energy Magazine”

Load Centers

- Traditional 450 VAC switchgear
 - May need modification for limited fault current
- Normally powered by PCM 1A.
 - Breaker to next zone Load Center (LC) normally open
- Upon loss of PCM 1A
 - Machinery Control System switch source to the next zone's LC
 - May require load shedding
 - Possibly provide alternate source to IPMC for uninterruptible loads

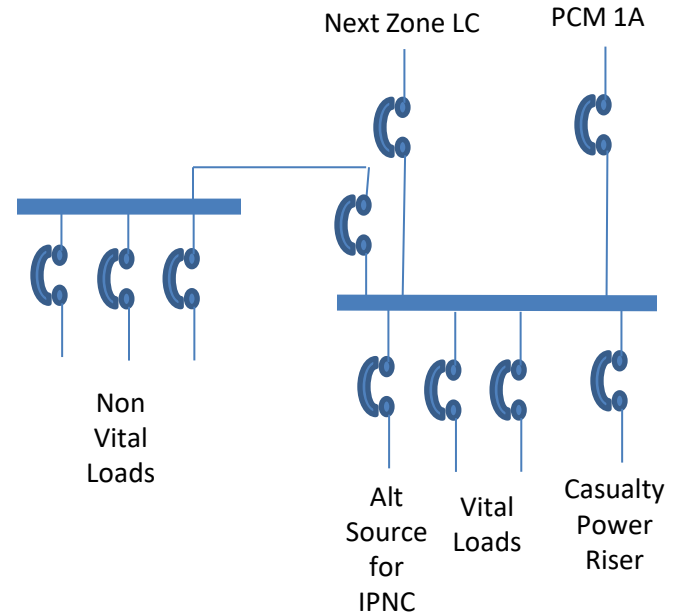

Integrated Power Management Center (IPMC)

- Update MIL-PRF-32272A
 - Include provision for energy storage for ~1 second
 - allow 450 VAC LCs in zone and in adjacent zone to reconfigure.
- Zone may have multiple IPMCs
- Supply
 - Un-interruptible loads
 - Supply loads with special power needs.
 - 400 Hz.
 - VSD motor loads
 - Low voltage DC Loads



Summary

- Power and energy density needs of a future destroyer with large pulse loads suggest a preference for MVDC
- An MVDC system must be affordable
- A number of technical issues need to be resolved in the next decade

