

Design Considerations for a Reference MVDC Power System

*SNAME Maritime Convention 2016
November 1-5, 2016
Bellevue, Washington*

Dr. Norbert Doerry
Dr. John Amy

Setting the Scene

“In FY2030, the DON plans to start building an affordable follow-on, multi-mission, mid-sized future surface combatant to replace the Flight IIA DDG 51s that will begin reaching their ESLs [Estimated Service Life] in FY2040.”

Report to Congress on the Annual Long-Range Plan for Construction of Naval Vessels for FY2015

Big differences from DDG 51:

- High-energy weapons and sensors
- Flexibility for affordable capability updates



Photo by CAPT Robert Lang, USN (Ret), from site <http://www.public.navy.mil/surfor/swmag/Pages/2014-SNA-Photo-Contest-Winners.aspx>

High Energy Mission Systems Integration Challenge

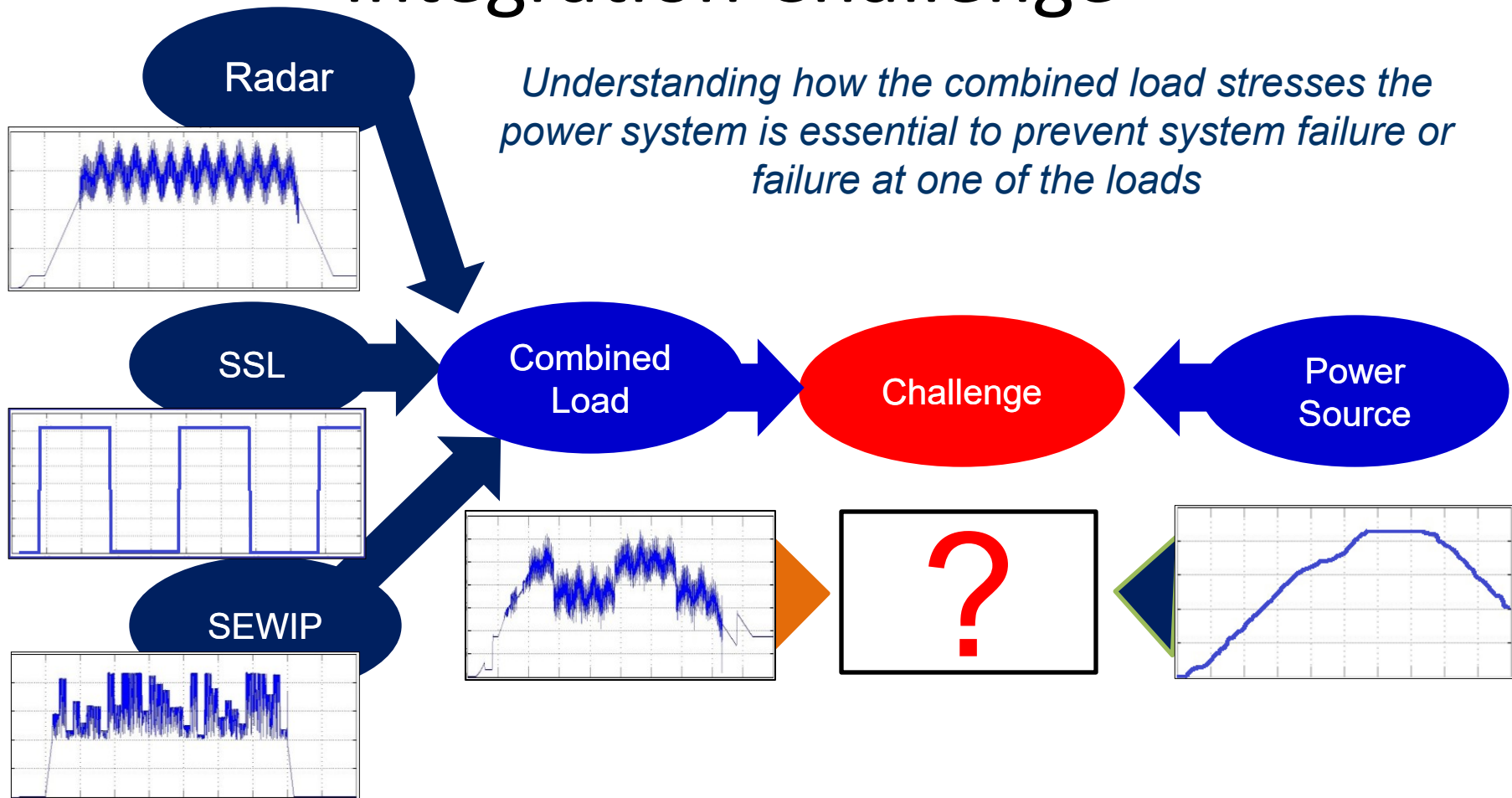

Ships cannot support High Power Systems without modifications to the ship's Electric Power System and other ship systems

Why Medium Voltage DC?

- Decouple prime mover speed from power quality
 - Minimize energy storage
- Power conversion can operate at high frequency – Improve power density
- Potentially less aggregate power electronics
 - Share rectification stages
- Cable ampacity does not depend on power factor or skin effect
- Power Electronics can control fault currents
 - Use disconnects instead of circuit breakers
- Acoustic Signature improvements
- Easier and faster paralleling of generators
 - May reduce energy storage requirements
- Ability to use high speed power turbines on gas turbines

Affordably meet electrical power demands of future destroyer

An AC Integrated Power System would likely require future destroyer to displace greater than 10,000 mt

MVDC Reference Architecture

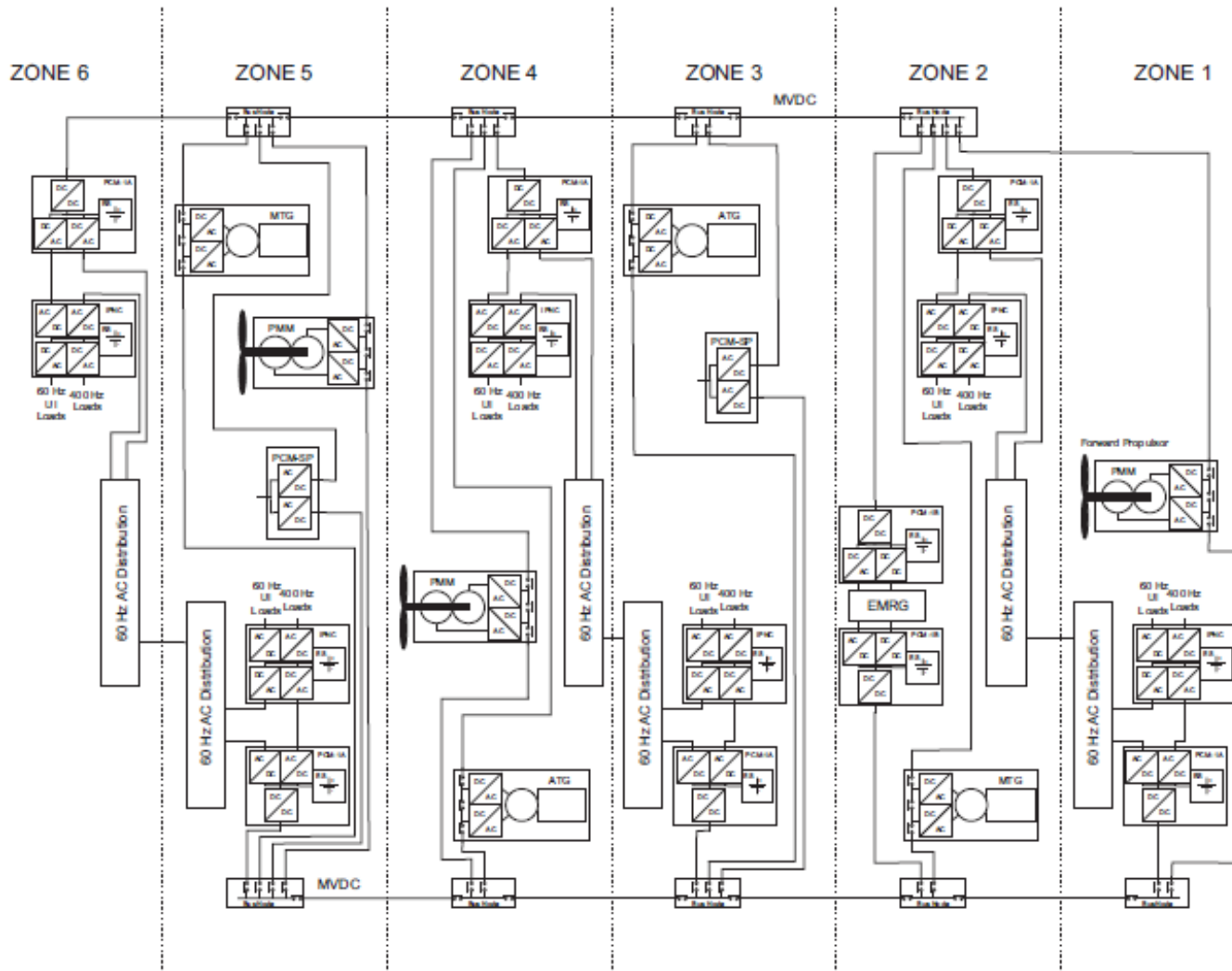

MVDC Voltage Standards

- MVDC nominal voltages based on IEEE 1709
 - 6000 VDC
 - 12000 VDC
 - 18000 VDC
- Current levels and Power Electronic Devices constrain voltage selection
 - 4000 amps is practical limit for mechanical switches
 - Power electronic device voltages increasing with time (SiC will lead to great increase)
- For now, 12000 VDC appears a good target ...
- Power Quality requirements TBD

Bus Nodes

- Segment MVDC Bus
 - Disconnects
- Isolate loads
 - Disconnects
- Isolate sources
 - Breaker
 - Disconnect if Breaker functionality in source
- Establishes Ground Reference for MVDC Bus
 - If functionality not provided in source

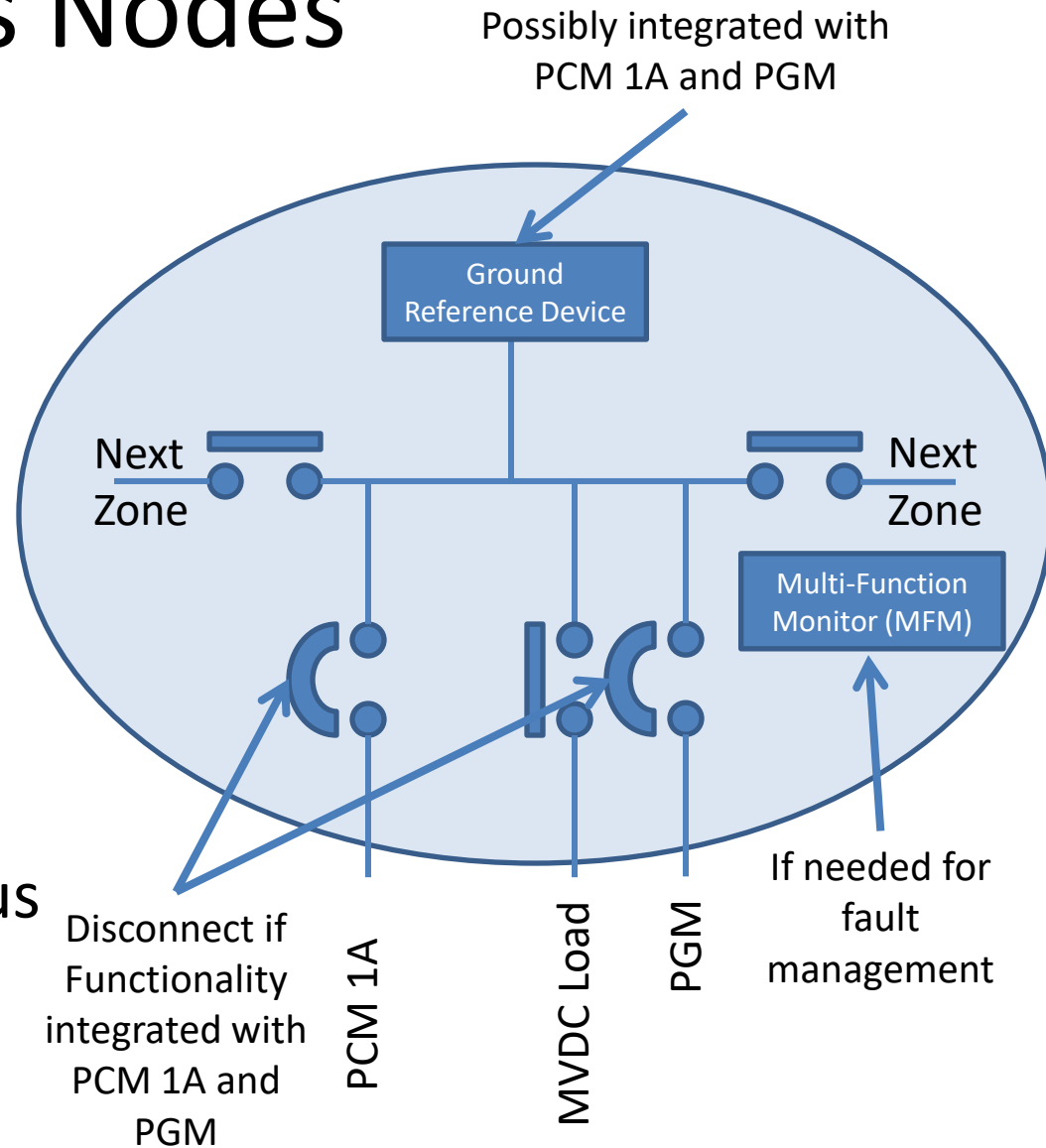

Power Generation Modules

- Split Windings
 - Reduced Impact on prime mover due to fault on one MVDC bus
 - Simplifies “odd number of generators” dilemma
 - May enable reducing ampacity of MVDC bus
- Consider Fuel Cells in the future

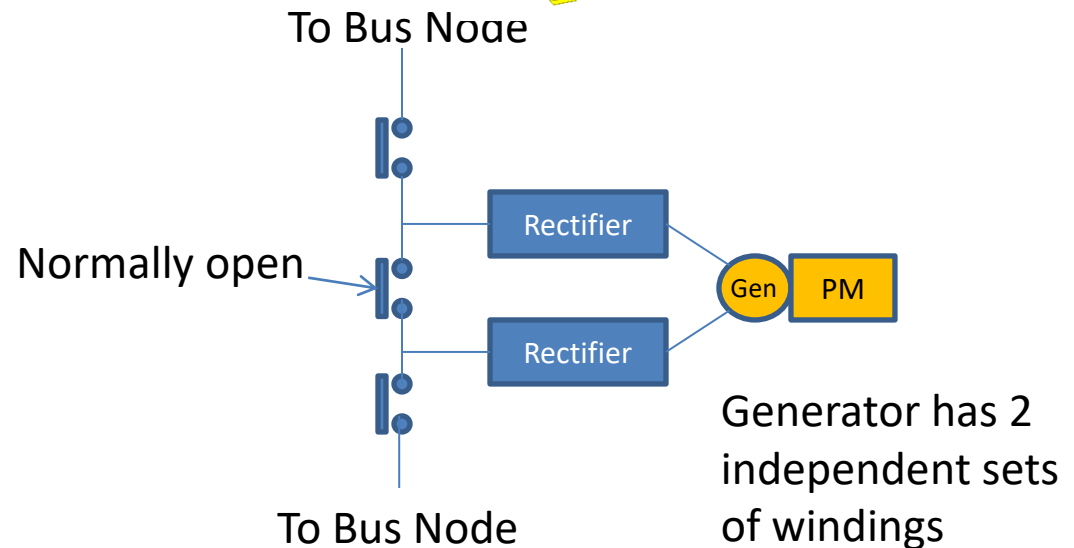
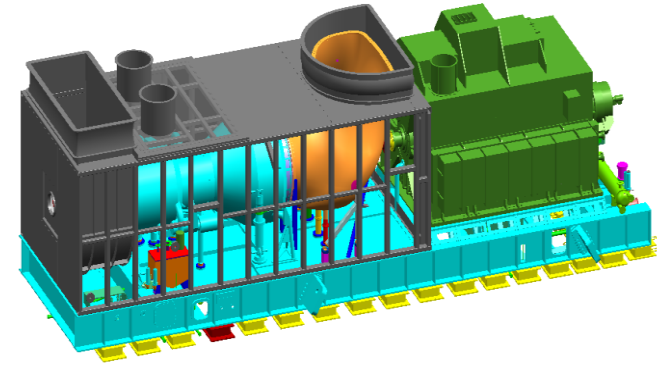

Propulsion Motor Modules

- Typically two motors for reliability
 - May share housing
- Normally powered by both MVDC busses
- Requires control interface for load management
- Consider contra-rotating propellers for fuel efficiency and minimizing installed electrical power generation capacity

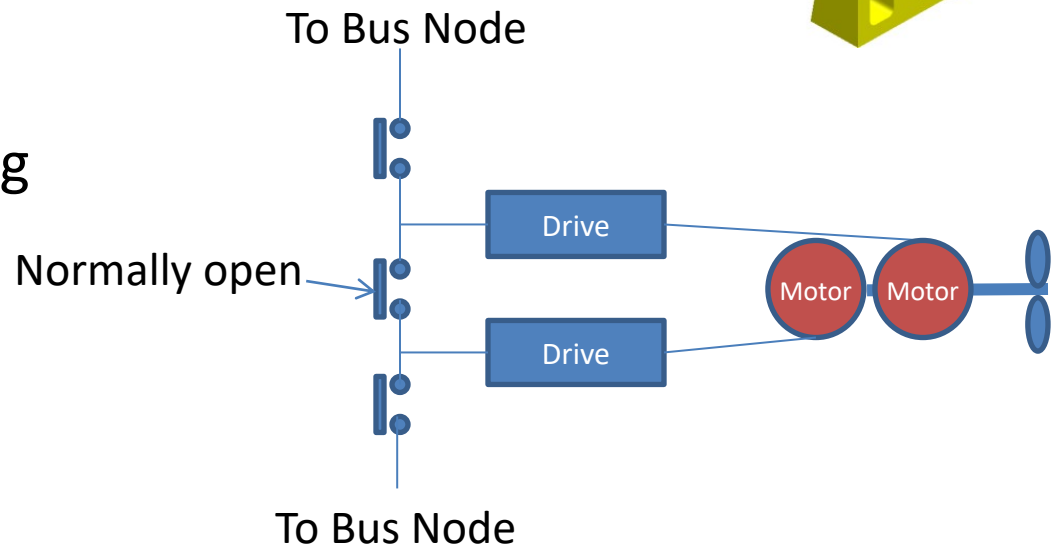
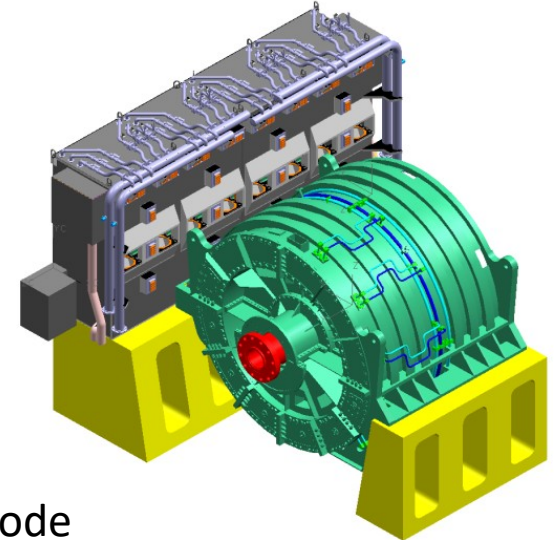

PCM-1A

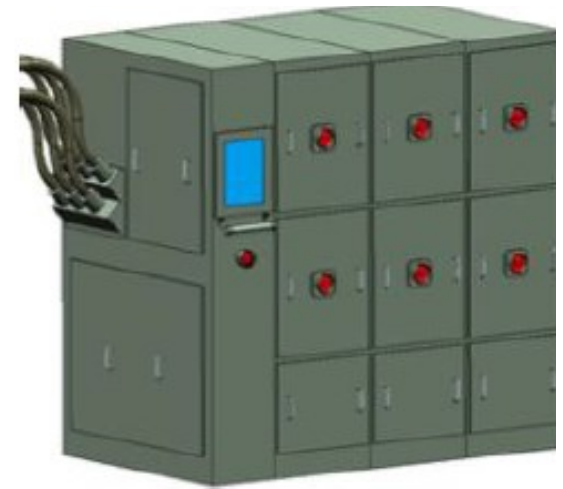
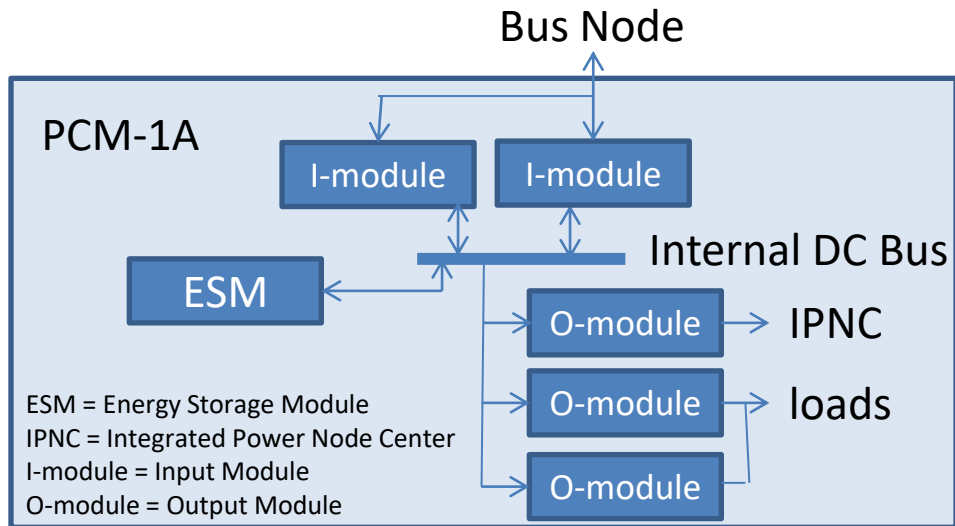

- Protects the MVDC bus from in-zone faults
- Provides hold up power while clearing faults on the MVDC Bus
- If desired, provides hold up power while standby generator starts
- If desired, contributes to energy storage for pulse power loads
- Provides conditioned power to loads
- Provides power to loads up to several MW (Lasers, Radars, Electronic Warfare)
- Provides power to “down-stream” power conversion (IPNC)
- Near term applications could use I-modules with AC inputs in “Energy Magazine” configuration

Integrated Power Node Center (IPNC)

- Update MIL-PRF-32272
 - Include 1000 VDC input modules
 - Include provision for energy storage for ~1 second
 - allow 450 VAC LCs in zone and in adjacent zone to reconfigure.
- Zone may have multiple IPNCs
- Supply
 - Un-interruptible loads
 - Supply loads with special power needs.
 - 400 Hz.
 - VSD motor loads
 - Perhaps Low voltage DC Loads



Notional Electromagnetic Railgun

- PCM-1B = Modular Power Conversion
 - 10's of MW
 - Powers Mount equipment in addition to Pulse Forming Networks (PFN)
- Normally powered by both MVDC busses
- Requires control interface for load management

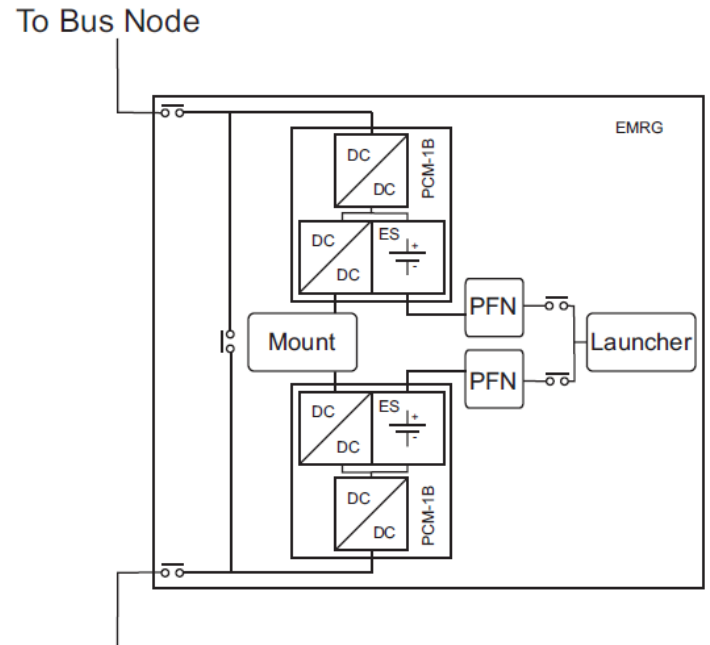

Issues needing resolution

- Power Management
- Energy Storage / Energy Management
- System Stability
- Bus Regulation
- Prime Mover Regulation
- Fault Detection, Localization and Isolation
- System Grounding
- Magnetic Signature
- Affordability

Need resolution by 2025 to support 2030 Lead Ship Contract Award

Summary

- Power and energy density needs of a future destroyer with large pulse loads suggest a preference for MVDC
- An MVDC system must be affordable
- A number of technical issues need to be resolved in the next decade

